

Stock code:301528

DOPPLER[®]

DOPPLER ELECTRONIC TECHNOLOGY

Serve society and benefit human security
Build a world-class NDT brand

Guangzhou Doppler Electronic Technologies Inc



Http: //www.cndoppler.com



E-mail: cndoppler@cndoppler.com



TEL: 020-82260495 82086632



FAX: 020-82086200



ADD: Doppler Building, No.1501 Kaichuang Avenue, Huangpu District, Guangzhou



PRODUCT MANUAL



COMPANY PROFILE

Doppler took the lead in realizing the **localization** of ultrasonic phased array instruments and probes, breaking the foreign monopoly

3D-TFM imaging technology and related manufacturing technology have reached the international leading level

Successfully overcome the industry problem of **256-channel** parallel transmission/reception

Established in 2008, Guangzhou **Doppler** Electronic Technologies INC (stock code: 301528) is a professional provider of industrial nondestructive testing (NDT) equipment and integrated solutions. Listed on the Growth Enterprise Market of the Shenzhen Stock Exchange in 2023, the company is recognized as a national “specialized and innovative” Little Giant and high-tech enterprise.

Doppler specializes in ultrasonic phased array instruments, automated inspection systems, high-end probes, and customized analysis software, and has achieved breakthroughs in 3D real-time high-resolution TFM technology and 256-channel parallel transmission/reception systems, reaching internationally advanced standards.

In parallel, Doppler has strengthened its capabilities in industrial radiographic testing. Its digital radiography (DR) and computed tomography (CT) systems are widely used in aerospace, automotive, new energy batteries, pressure vessels, castings, welded structures, and precision electronics. With high-resolution imaging, AI-assisted analysis, and automated inspection integration, Doppler delivers efficient, reliable solutions for both laboratory evaluation and high-volume production environments, supporting stringent quality and traceability requirements across advanced manufacturing industries.

Application

- Special equipment
- Nuclear energy
- Aerospace
- Heavy machinery
- Energy and electricity
- Petroleum petrochemical
- Research institutions
- Transportation
- New energy vehicles
- Testing institutions



CONTENTS

01	INSTRUMENT PRODUCTS	01	03	SCANNER PRODUCT	47		
NOVASCAN L3 Phased Array Ultrasonic Detector		03	Corrosion And Base Metal Inspection	49	· CRS7/CRS8 Chain Scanner (Small Pipes)	56	
NOVASCAN V3 Phased Array Ultrasonic Detector		05	· MOS08 Chain Axial Step Scanner	49	· CRS-25 Chain Scanner (Small/Medium Pipes)	57	
NOVASCAN V2 Phased Array Ultrasonic Detector		07	· DSC06 Corrosion Scanner	50	· MOS04 Chain Scanner (Large Pipes)	58	
NOVASCAN V1 Phased Array Ultrasonic Detector		09	· FS04 Axial Straight Pipe Flexible Probe Scanner	50	· DSC27 Guide Rail Scanner	59	
PHASCAN II Portable Phased Array Flaw Detector		11	· FS06 Elbow Scanner	50	· MOS07 Nozzle Weld Scanner	59	
FLEXSCAN Portable Phased Array Flaw Detector		13	· LS03 Wheel Scanner	51	· DSC52 Tube-Sheet Scanner	60	
ROBUST P Series Phased Array Ultrasonic Testing Board		15	· DSC03 Automatic Crawler Scanner	51	Encoder	61	
ROBUST M1 Multi-Channel Ultrasonic Board		17	Weld Inspection	53	· ENC-10 Wheel Encoder	61	
ROBUST S1 Single Channel Ultrasonic Board		19	· MOS01 Mouse-Type Scanner	53	· LX14 Cable-Encoder	61	
ROBUST F1 Phased Array Ultrasonic Board		21	· CCE-2 Simple Scanner	53	PE Pipe Butt Joint Inspection	62	
ROBUST L1 Small Phased Array Ultrasonic Board		23	· MOS03 Dual Probes Scanner	54	· MOS05-D PE Pipe Heat Fusion Scanner	62	
Nexus F1 Pulser-Receiver		25	· FC14 Axial/Longitudinal Weld Scanner	55	· MOS05-B PE Pipe Electrofusion Scanner	63	
Application Case		27	· FC30 Manual Weld Inspection Scanner	55	· PE01 PE Pipe Electrofusion Joint Scanner	64	
02	INDUSTRIAL ARRAY PROBE	29	04	CONVENTIONAL UT PROBE	65		
Linear Array Probe Series	33	R-Angle Probe Series/Concave Array Probe Series	40	Contact Probe	70	Air-Coupling Probes	89
Near-Wall Probe Series/Immersion Probe Series	34	Bolt Probe Series/Spot Welding Probe Series	41	Immersion Probe	84	Probes for Custom and Specific Applications	90
Laterally Focused Array Probe Series	35	Dual-Linear Array/Dual-Matrix /Wind Power Probe Series	42	Hyperbolic Ultrasonic Transducer	87	Cables/Adapters	93/94
Immersion Probe Series/Matrix Array Probe Series	36	Other Special Probes	43				
Integrated Wedge Probe Series/Water Bag Probe Series	37	Selection Of Industrial Array Probe	44				
Soft Protective Film Probe Series/Wheel Probe Series	38	Wedge	45				
Flexible Probe Series/High Temperature Probe Series	39	Connectors & Adapters	46				



01 INSTRUMENT PRODUCTS

- NOVASCAN L3 Phased Array Ultrasonic Detector
- NOVASCAN V3 Phased Array Ultrasonic Detector
- NOVASCAN V2 Phased Array Ultrasonic Detector
- NOVASCAN V1 Phased Array Ultrasonic Detector
- PHASCAN II Portable Phased Array Flaw Detector
- FLEXSCAN Portable Phased Array Flaw Detector
- ROBUST P Series Phased Array Ultrasonic Testing Board
- ROBUST M1 Multi-Channel Ultrasonic Board
- ROBUST S1 Single Ultrasonic Board
- ROBUST F1 Phased Array Ultrasonic Board
- ROBUST L1 Small Phased Array Ultrasonic Board
- Nexus F1 Pulser-Receiver
- Application Case

NOVASCAN L3

Phased Array Ultrasonic Detector

/01

Lightweight & Portable

Only 2.7 kg, ideal for working at height, confined spaces, and outdoor inspections.

/03

High-Speed & Accurate

PRF up to 20 kHz for efficient scanning.
0.5-20 MHz bandwidth.
800% A-scan display height.

/02

Cost-Effective Performance

Delivers professional inspection capability at a competitive cost.

/04

Multi-Mode in One Unit

Integrated PA, UT, FMC-TFM, and TOFD modes.
Suitable for weld inspection, thickness measurement, and flaw detection.



NOVASCAN L3 Performance

Parameter	PA Module	Conventional UT
Configuration		
Receive/Transmit	32/64PR, 16/64PR	1 / 1
Velocity	340-15240m/s	340-15240m/s
Pulser		
Test Mode	PE / PC	PE / PC / TT / TOFD
Voltage	10V-100V / 1V	100V / 200V / 400V
Pulse Shape	Negative Square Wave	Negative Square Wave
Pulse Width	20-1000ns/2.5ns	30-1000ns/2.5ns
Rise Time	<4ns	<8ns
PRF	20KHz	10KHz
Delay	20µs/2.5ns	20µs/2.5ns
Receiver		
Gain	0-120dB	0-120dB
Bandwidth	0.5-20MHz	0.5-20MHz
Delay	20µs/2.5ns	20µs/2.5ns
Data Acquisition		
Sampling Rate	100MHz	100MHz
ADC	16bit	14bit
Focus Type	True Depth/Sound Path/Projection/Focal Plane/dynamicfocus	NA
Rectification Mode	FW/HW+/HW-/RF	FW/HW+/HW-/RF
Maximum A-scan	16384	16384
Scan/Display		
Type	TFM/Linear/Sectorial/Compound scanning	NA
Display Mode	A/B/C/S/FMC-TFM/3D/TopC/Band chart	A/B/C/Band chart
Unit	mm/inch	mm/inch
TCG		
Point	16	16
Gain Range	40dB	40dB
Max Gain Slope	40dB/10ns	40dB/µs

Parameter	PA Module
Gate	
Number	A/B/C/I+Custom Gate
Threshold	0-100%
Report	
Report	WORD、PDF、EXCEL
Display Screen	
Size	10.1 inch
Resolution	1920x1200 pixel
Type	Industrial TFT LCD Touch Screen
I/O Port	
USB	2 USB3.0
Ethernet	1;1000Mb/s
Video Output	HDMI 1.4b
Encoder	RL 16-pin
Language	
Language	Chinese/English/Russian/French/German/Italian
Power Supply	
DC Supply Voltage 15V DC	
Battery Type	Lithium battery10.8V 97.2Wh
Continuous Working Time	About 4 hours
Case	
Size	302mm×230mm×84mm
Weight	2.7Kg (excluding battery)
IP level	
IP level	IP65

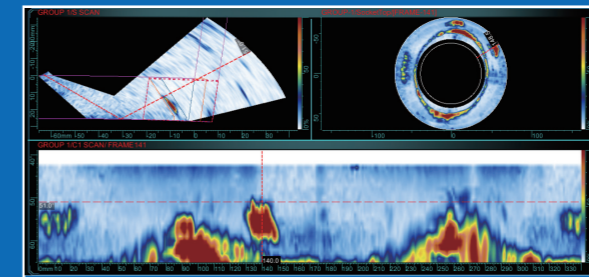

Dedicated imaging algorithm support

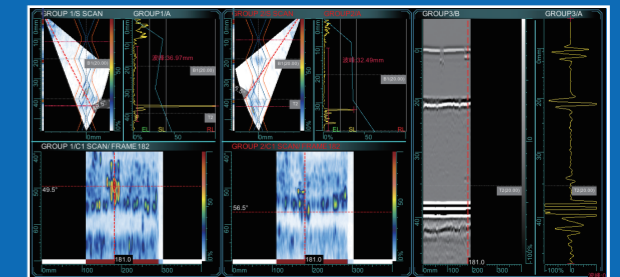

Integration of multiple detection modes

Phased Array Ultrasonic Detector

/01

Upgraded Performance

200V pulse voltage, 0.18–27 MHz ultra-wide bandwidth. More realistic signal reproduction.

/03

Real-Time Imaging & AIM

Real-time TFM with FMC data export. AIM sound field map for optimized setup and higher sensitivity.

/02

Full Technology Integration

UT, TFM (FMC / PWI / 3D), PCI (FMC / PWI), and TOFD.

/04

Industrial-Grade Design

IP65 protection with WiFi and Bluetooth. Open architecture for secondary development. Includes all V2 functions.

Model	FMC-PCI/ PWI-PCI	AIM Acoustics Impact Diagram	DMA/ DLA-TFM	Physics Shortcut keys	Bandwidth Range	Maximum Emission Voltage	Wave Height	Number of Alert Groups
NOVASCAN V3	✓	✓	✓	✓	0.18-27MHz	200V/1V	1600%	3
NOVASCAN V2	✗	✗	✗	✗	0.3-25MHz	120V/10V	800%	1



NOVASCAN V3 Performance

Parameter	PA Module	Conventional UT
Configuration		
Receive/Transmit	32/128PR, 64/128PR, 64/64PR	2 / 2
Velocity	340-15240m/s	340-15240m/s
Pulser		
Test Mode	PE / PC	PE / PC / TT / TOFD
Voltage	10V-200V / 1V	100V / 200V / 400V
Pulse Shape	Bipolar Square Wave/ Negative Square Wave	Negative Square Wave
Pulse Width	20-1250ns/2.5ns	25-1000ns/2.5ns
Rise Time	<10ns	<10ns
PRF	40KHz	24KHz
Delay	20µs/2.5ns	20µs/2.5ns
Receiver		
Gain	0-120dB	0-120dB
Bandwidth	0.18-27MHz	0.2-30MHz
Delay	20µs/2.5ns	20µs/2.5ns
Data Acquisition		
Sampling Rate	200MHz	200MHz
ADC	16bit	16bit
Focus Type	True Depth/Sound Path/Projection/ Focal Plane/dynamicfocus	NA
Rectification Mode	FW/HW+/HW-/RF	FW/HW+/HW-/RF
Maximum A-scan	16384	16384
Scan/Display		
Type	TFM/Linear/Sectorial/ Compound scanning	NA
Display Mode	A/B/C/S/FMC-TFM/PWI-TFM/ 3D/TopC/Band chart	A/B/C/Band chart
Unit	mm/inch	mm/inch
TCG		
Point	16	16
Gain Range	0~40dB	0~40dB
Max Gain Slope	40dB/10ns	40dB/µs

Parameter	PA Module
Gate	
Number	Unlimited
Threshold	0-100%
Report	
Report	WORD、PDF、EXCEL
Data Storage	
ROM	Flash Drive/SSD(built-in) 1T
Display Screen	
Size	12.1 inch
Resolution	1280x800 pixel
Type	Industrial TFT LCD Touch Screen
I/O Port	
USB	2 USB3.1 + 1 USB2.0
Ethernet	1;1000Mb/s
Video Output	HDMI
Encoder	LEMO 16-pin
Language	
Language	Chinese/English/Russian/French/German/Italian
Power Supply	
DC Supply Voltage	15V DC
Battery Type	Lithium battery10.8V 97.2Wh (Support hot plugging)
Continuous Working Time	About 5 hours
Case	
Size	362mm×254mm×121mm
Weight	4.9Kg (Excluding battery)
IP level	
IP level	IP65

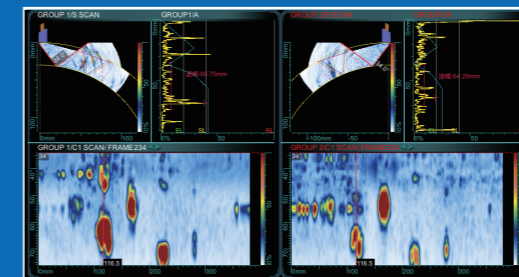

Pipeline longitudinal seam inspection

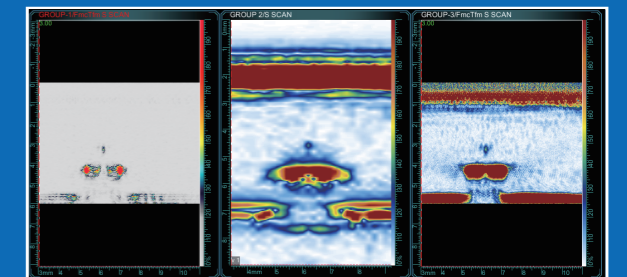

Copper, φ0.1mm flat bottom hole, FMC-PCI(left), PA(center), FMC-TFM(right)

Phased Array Ultrasonic Detector

/01

Upgraded Performance & Easy Operation

Higher pulse voltage, wider bandwidth, faster sampling; optimized UI for efficient workflow.

/03

Multi-Modal Inspection

FMC/TFM · PWI/TFM · PAUT · UT · TOFD · One platform for all scenarios.

/02

High-Speed Acquisition

128 channels · 40 kHz PRF · Real-time processing · High precision.

/04

3D Imaging & Smart Analysis

3D matrix TFM · Intelligent defect recognition · Large-capacity storage · Fast data engine



NOVASCAN V2 Performance

Parameter	PA Module	Conventional UT
Configuration		
Receive/Transmit	32/128PR, 64/128PR, 64/64PR	2 / 2
Velocity	340-15240m/s	340-15240m/s
Pulser		
Test Mode	PE / PC	PE / PC / TT / TOFD
Voltage	20V-120V / 10V	100V / 200V / 400V
Pulse Shape	Bipolar Square Wave	Negative Square Wave
Pulse Width	20-1250ns/2.5ns	25-1000ns/2.5ns
Rise Time	<10ns	<10ns
PRF	40KHz	24KHz
Delay	20µs/2.5ns	20µs/2.5ns
Receiver		
Gain	0-120dB	0-120dB
Bandwidth	0.3-25MHz	0.3-25MHz
Delay	20µs/2.5ns	20µs/2.5ns
Data Acquisition		
Sampling Rate	200MHz	200MHz
ADC	16bit	16bit
Focus Type	True Depth/Sound Path/Projection/Focal Plane/dynamicfocus	NA
Rectification Mode	FW/HW+/HW- /RF	FW/HW+/HW- /RF
Maximum A-scan	16384	16384
Scan/Display		
Type	TFM/Linear/Sectorial/Compound scanning	NA
Display Mode	A/B/S/C/FMC-TFM/PWI-TFM/3D/TopC/Band chart	A/B/C/Band chart
Unit	mm/inch	mm/inch
TCG		
Point	16	16
Gain Range	40dB	40dB
Max Gain Slope	40dB/10ns	40dB/µs

Parameter	PA Module
Gate	
Gate	A/B/C/I + Custom Gate
Threshold	0~100%
TFM	
Point	1024 x 1024
Report	
Report	WORD、PDF、EXCEL
Data Storage	
ROM	Flash Drive/SSD(built-in) 1T
Display Screen	
Size	12.1 inch
Resolution	1280x800 pixel
Type	Industrial TFT LCD Touch Screen
I/O Port	
USB	2 USB3.0 + 1 USB2.0
Ethernet	1;1000Mb/s
Video Output	HDMI
Encoder	LEMO 16-pin
Multifunctional Interface	LEMO 14-pin
Language	
Language	Chinese/English/Russian/French/German/Italian
Power Supply	
DC Supply Voltage	15V DC
Battery Type	Lithium battery10.8V/97.2Wh (Hot Plug Support)
Continuous Working Time	About 5 hours
Case	
Size	362mm×254mm×121mm
Weight	4.9Kg(excluding battery)
IP level	
IP level	IP65

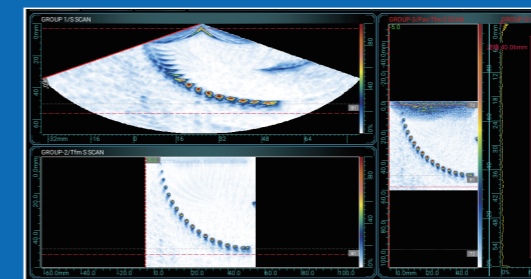

Comparison of PA, FMC-TFM and PWI-TFM imaging

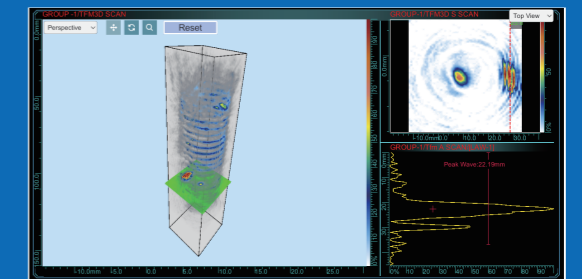

Bolt 3D TFM inspection

Phased Array Ultrasonic Detector

/01

Multi-Mode Real-Time Imaging

FMC-TFM · PWI-TFM (real-time) · PA · Dual-channel TOFD/UT synchronous detection.

/03

Simulation & Intelligent Analysis

3D simulation · Real-time section update for nozzle inspection · Guided setup · Bonding & corrosion AI recognition.



/02

Full-Scene Adaptation

Linear & matrix arrays · Corrosion · Welds · Pipelines · Tanks · Software upgradeable.

/04

Industrial-Grade Design

IP65 aluminum housing · -10 ° C to 45 ° C · Dual batteries · 5h continuous operation.

NOVASCAN V1 Performance

Parameter	PA Module	Conventional UT
Configuration		
Receive/Transmit	32/128PR, 32/64PR	2 / 2
Velocity	340-15240m/s	340-15240m/s
Pulser		
Test Mode	PE / PC	PE / PC / TT / TOFD
Voltage	50V / 100V	100V / 200V / 400V
Pulse Shape	Negative Square Wave	Negative Square Wave
Pulse Width	25-1000ns/2.5ns	25-1000ns/2.5ns
Rise Time	<8ns	<8ns
PRF	40KHz	24KHz
Delay	20μs/2.5ns	20μs/2.5ns
Receiver		
Gain	0-120dB	0-120dB
Bandwidth	0.5-20MHz	0.5-20MHz
Delay	20μs/2.5ns	20μs/2.5ns
Data Acquisition		
Sampling Rate	100MHz	100MHz
NO.of Focal Laws	512	NA
Focus Type	True Depth/Sound Path/ Projection/Focal Plane	NA
Rectification Mode	FW/HW+/HW-/RF	FW/HW+/HW-/RF
Maximum A-scan	16384	16384
Scan/Display		
Type	Linear/sector scan/ compound scan/TFM A/B/C/S/FMC-TFM/ PWI-TFM/3D/TopC/Band chart	NA
Display Mode	A/B/C/ Band chart	A/B/C/ Band chart
Unit	mm/inch	mm/inch

Parameter	PA Module
IP level	
IP level	IP65

Parameter	PA Module	Conventional UT
TCG		
Point	16	16
Gain Range	40dB	40dB
Max Gain Slope	40dB/μs	40dB/μs

Parameter	PA Module
Report	
Report	WORD、PDF、EXCEL
Data Storage	
ROM	Flash Drive/SSD(built-in) 128G
Single File Size	4G
Display Screen	
Size	10.4 inch
Resolution	1024×768 pixel
Visible Area	211mm×158mm
Type	Industrial IPS Capacitive Touch Screen
I/O Port	
USB	2
Ethernet	1;1000Mb/s
WIFI	Support USB External WIFI Transmission Customization
Video Output	HDMI 1.4b
Encoder	LEMO 16-pin
Language	
Language	Chinese/English/French/ German/Russian/Italian
Power Supply	
DC Supply Voltage	15V DC
Battery Type	Lithium battery 11.25V/99.6Wh
Continuous Working Time	About 5 hours
Case	
Size	360mm×260mm×130mm
Weight	6Kg(excluding battery)

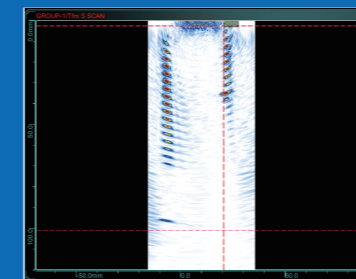

Bolt FMC-TFM inspection

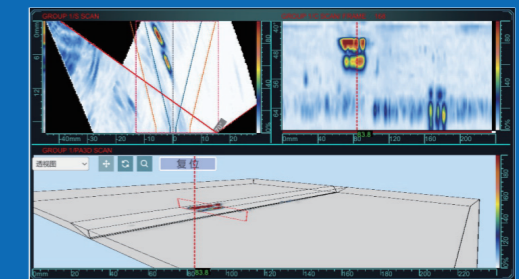

PA-3D Scanning



Portable Phased Array Flaw Detector

/01

Advanced Scanning Upgrade

Dual-axis scanning · 3D simulation · Multi-touch precise control.

/03

64/128 High-Speed Architecture

Multi-channel parallel processing · Ultra-fast synchronous acquisition · Optimized for thick & high-attenuation structures.

/02

Full-Spectrum Probe Compatibility

0.5-20 MHz broadband · DLA & DMA arrays · Custom solutions for metal/non-metal.

/04

Dynamic Depth Focus (DDF)

Full-depth high resolution · Enhanced SNR · Clear imaging for welds & composite laminates.



PHASCAN II Performance

Parameter	PA Module	Conventional UT
Configuration		
Receiver/Pulser	32/128PR	2 / 2
Velocity	635-15240m/s	635-15240m/s
Pulser		
Test Mode	PE / PC	PE / PC / TT / TOFD
Voltage	50 / 100V	100V / 200V / 400V
Pulse Shape	Negative Square Wave	Negative Square Wave
Pulse Width	30-500ns	30-500ns
Rise Time	<8ns	<8ns
PRF	20KHz	11KHz
Delay	10µs / 2.5ns	10µs / 2.5ns
Receiver		
Gain	0-80dB	0-110dB
Bandwidth	0.5-20MHz	0.5-20MHz
Delay	10µs / 2.5ns	10µs / 2.5ns
Data Acquisition		
Sampling Rate	100MHz	100MHz
Max A-scan Points	32768	32768
No. of Focal Laws	1024	NA
Focus Type	True Depth/Sound Path/Projection/Focal Plane	NA
Scan/Display		
Type	Linear/sectoral scan	NA
Display Mode	A/B/C/S Scanning	A/B/C
Unit	mm / inch	mm/inch

Parameter	PA Module
TCG	
Point	16
Gain Range	40dB
Max Gain Slope	40dB/µs

Parameter	PA Module
Report	
Report	HTML
Data Storage	
Pluggable Memory	Flash Drive/SD card / SSD(Built-in)
Display Screen	
Size	10.4 inch
Resolution	800*600pixel
Type	Industrial TFT LCD Capacitive Touch Screen
I/O Port	
USB	3
Ethernet	1000Mb/s
Video Output	DVI/HDMI
Encoder	DB15; Dual axis
Language	
Language	Chinese/English/Russian
Power Supply	
DC Supply Voltage	15V DC
Battery Type	Lithium battery (Hot Plug Support)
Continuous Working Time	About 6 hours
Case	
Size	325mm×230mm×130mm
Weight	4.5Kg(Excluding battery)
Hardware	
CPU	4 × 1.2GHz
Flash Drive	FAT32 / NTFS
Storage Capacity	128GB
Software	
2D C-scan / 3D Acoustic Beam Simulation/Matrix array	Support
Model import/projection	Support
C scan /TKY real-time loading	Support
Multi-point operation of real-time 3D display interface	Support
Secondary development/online monitoring/single file size	Support/Support /1GB

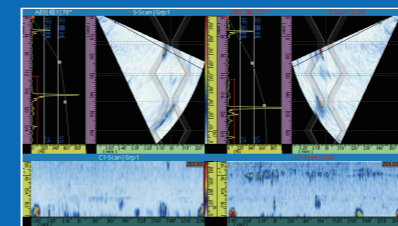

Multi-group scanning

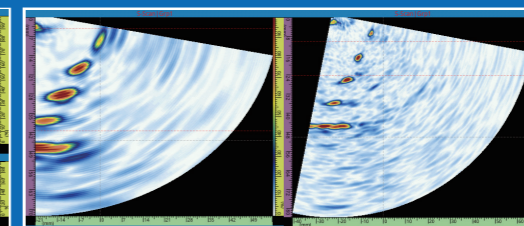

DMA/DLA inspection

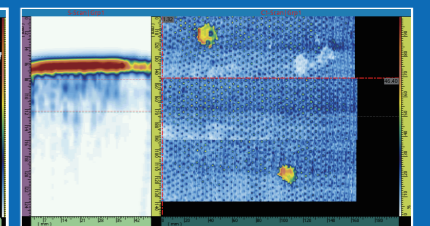

Two-dimensional scanning



Portable Phased Array Flaw Detector

/01

Compact Multi-Modal Platform

PAUT · TOFD · UT · Bolt inspection · 64 independent Tx channels
· Cost-effective all-in-one solution.

/03

Lightweight & Field-Ready

3.5 kg portable design · Ideal for aerial work, towers & pipe racks · Strong environmental adaptability.

/02

Dual-System Intelligent Architecture

Unique "PAUT + Bolt" dual-engine design · Fast mode switching
· Flexible task response.

/04

Smart Operation & Visualization

Preset bolt programs · One-key save/recall · Real-time 3D imaging · Color-coded defect identification.



FLEXSCAN Performance

Parameter	PA Module	Conventional UT
Configuration		
Receive/Transmit	32/64PR	1 / 2
Velocity	635-15240m/s	635-15240m/s
Pulser		
Test Mode	PE / PC	PE / PC / TT / TOFD
Voltage	50V / 100V / 130V	100V / 200V / 400V
Pulse Shape	Negative Square Wave	Negative Square Wave
Pulse Width	30-500ns	30-500ns
Rise Time	<8ns	<8ns
PRF	20KHz	6KHz
Delay	10μs / 2.5ns	10μs / 2.5ns
Focus Type	True Depth/Sound Path/ Projection/Focal Plane	NA
Receiver		
Gain	0-80dB	0-110dB
Bandwidth	0.5-18MHz	0.5-20MHz
Receiving Delay	10μs / 2.5ns	10μs / 2.5ns
Scan/Display		
Type	Linear/sector scanning	NA
Display Mode	A/B/C/S Scanning	A/B
Unit	mm/inch	mm/inch

Parameter	PA Module
TCG	
Point	16
Gain Range	40dB
Max Gain Slope	40dB/μs

Parameter	PA Module
Report	
Report	Web
Data Storage	
Pluggable Memory	Flash Drive/SD card
Display Screen	
Size	8.4 inch
Resolution	800*600 pixel
Type	Industrial TFT LCD touch screen
I/O Port	
USB	2
Internet	100Mb/s
Video Output	HDMI
Encoder	LEMO 16-pin; Uniaxial
Language	
Language	Chinese/English/Russian
Power Supply	
DC Supply Voltage	15V DC
Battery Type	
Continuous Working Time	About 4 hours
Case	Lithium battery (Hot Plug Support)
Size	296mm×209mm×89mm
Weight	3.5Kg(Excluding battery)

Board series

ROBUST P Series Phased Array Ultrasonic Testing Board

/01

High-Performance Automatic Detection Platform

ROBUST P1/P2/P3 phased array boards · Widely applied in manufacturing, aerospace, transportation & new energy · Enable efficient quality control and production optimization.

/03

Flexible Multi-Mode & SDK Support

PA · UT · TFM (FMC/PWI/3D) · PCI · TOFD · Free switching between TFM & PA · Dual independent TOFD (P2&P3) · Powerful SDK for fast system integration.

/02

64-Channel Parallel Upgrade (P2/P3)

Parallel architecture · 2-3× faster scanning than conventional mode · Enhanced efficiency for demanding applications.

/04

Customizable & Scalable Solutions

Synchronous multi-channel detection · Adaptable to mass production & aerospace-grade inspection · Flexible solutions for complex automatic testing tasks.

Model Comparison Overview

Model parameter	Channel configuration	Impulse voltage	Bandwidth	A-scan amplitude
ROBUST P1	32/128	20-100V/10V	0.9-20MHz	200%
ROBUST P2	64/128	20-120V/10V	0.35-25MHz	800%
ROBUST P3	64/128	10-200V/1V	0.18-27MHz	1600%



ROBUST P1



ROBUST P2



ROBUST P3

Performance

Parameter	(P1)	(P2)	(P3)
Configuration			
Receive/Transmit	32/128PR, 32/64PR, 16/64PR	32/128PR, 64/128PR	64/128PR, 64/64PR, 32/128PR, 32/64PR
Pulser			
Test Mode	PE / PC	PE / PC	PE / PC
Voltage	20~100V / 10V	20V-120V / 10V	10V-200V / 1V
Pulse Shape	Negative Square Wave	Bipolar Square Wave	Bipolar Square Wave
Pulse Width	25-1000ns/2.5ns	20-1250ns/2.5ns	20-1250ns/2.5ns
Rise Time	<8ns	<10ns	<10ns
PRF	40KHz	40KHz	40KHz
Delay	0-20µs/2.5ns	20µs/2.5ns	20µs/2.5ns
Receiver			
Gain	0-120dB	0-120dB	0-120dB
Bandwidth	0.9-20MHz	0.3-25MHz	0.18-27MHz
Delay	20µs/2.5ns	20µs/2.5ns	20µs/2.5ns
Data Acquisition			
Sampling Rate	100MHz	200MHz	200MHz
No.of Focal Laws	512	1024	1024
ADC	10bit	16bit	16bit
Maximum A-scan	16384	16384	16384
Scan/Display			
Detection Mode	PA/UT/TOFD/FMC-TFM/PWI-TFM/FMC-PCI/PWI-PCI		
Scanning Type	TFM/Linear/Sectorial/Compound scanning		
Display mode	A/B/S/C/TFM/3D/TopC/Band chart		
Measure	mm/inch		

Parameter	(P1)	(P2)	(P3)
Power			
DC	15V DC	15V DC	15V DC
TFM			
Point	4096*1024	1024*1024	1024*1024
TFM Aperture	128 launch	128 launch	128 launch
TFM Mode	TT,TTT,TTTT,LL,LLL,LLLL,TLT,TLL,LTT		
TCG			
Point	16	16	16
Gain Range	40dB	40dB	40dB
Max Gain Slope	40dB/µs	40dB/10ns	40dB/10ns
Gate			
Number	A/B/C/I + Customize	A/B/C/I + Customize	A/B/C/I + Customize
Threshold	0-100%	0-100%	0-100%
Gate trigger mode	Peak/leading edge	Peak/leading edge	Peak/leading edge
I/O Port			
Ethernet	1000 Mb/s	1000 Mb/s	1000 Mb/s
Encoder	LEMO 16-pin	Dual axis, LEMO 16-pin	Dual axis, LEMO 16-pin
Case			
Size	350x245x55mm	368.9x250.6x90.1mm	400x250x100mm
Weight	3.4Kg	5Kg	5Kg
Language			
Language	Chinese/English/French/German/Russian/Italian		

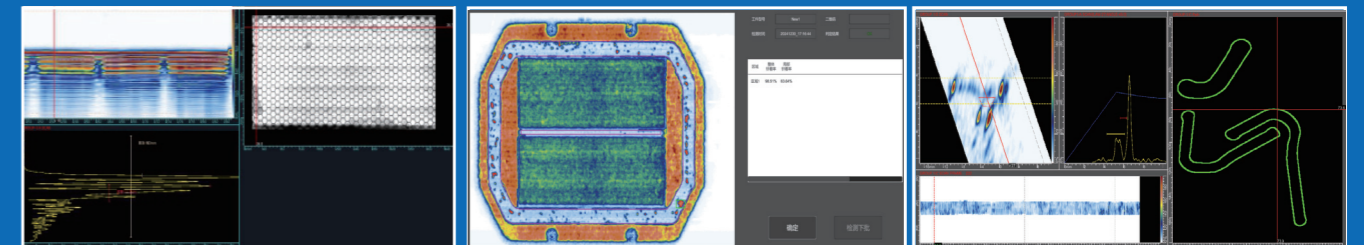

Two-dimensional scanning

Intelligent injury judgment

Multi-axis scanning

Board Series

ROBUST M1 Multi-Channel Ultrasonic Board

ROBUST M1 multi-channel ultrasonic board adopts advanced modular unit design to provide users with 4-channel and 8-channel standardized products, and can flexibly customize more channels according to requirements to meet personalized detection requirements. Each channel supports independent parallel sampling, which ensures high-efficiency and high-precision detection performance and significantly improves the overall detection efficiency and reliability. ROBUST M1 is widely used in industry, medical treatment, scientific research and other fields, providing accurate and reliable ultrasonic testing solutions for thickness measurement, defect detection and other applications.

/01

Modular Design And Flexible Expansion

The number of channels can be customized according to requirements, and the system can be upgraded to meet diversified detection requirements.

/03

High-Speed Detection Capability

Support the pulse repetition frequency of 96K (maximum 12K for a single UT), and adapt to automation application scenarios with high precision and speed requirements.

/02

Efficient Parallel Sampling Technology

Each channel samples independently to avoid interference and realize high-precision and high-speed real-time detection.

/04

Complete SDK And Customized Services

Provide SDK development kit and customized solutions to support automatic production line and quality control improvement.



Performance

Parameter	Parameter
Configuration	
Receive/Transmit	4/4, 8/8
Velocity	340-15240m/s
Pulser	
Test Mode	PE / PC / TT / TOFD
Voltage	100V / 200V / 400V
Pulse Shape	Negative Square Wave
Pulse Width	25-1000ns, Stepping 2.5ns
Rise Time	<8ns
PRF	96KHz / 48KHz
Delay	20μs/2.5ns
Receiver	
Gain	0-120dB
Bandwidth	0.3-25MHz
Delay	20μs/2.5ns
Data Acquisition	
Sampling Rate	100MHz
ADC	12bit
Maximum A-scan	16384
Rectification Mode	FW / HW+ / HW- / RF
Power Supply	
DC	15V DC

Parameter	Parameter
Scan/Display	
Display Mode	A / B / C / D / Band chart / FFT
Unit	mm / inch
DAC	
Point	16
TCG	
Point	16
Gain Range	40dB
Max Gain Slope	40dB/μs
Band filter	
Band filter	Support
Gate	
Gate	A/B/C/I + Custom gate
Threshold	0-100%
Gate trigger mode	Peak/leading edge
Report	
Report	WORD, PDF, EXCEL
I/O Port	
Ethernet	1000Mb/s
Encoder	LEMO 16-pin
Case	
Size	360.5mm × 200mm × 60.7mm
Weight	2.5Kg

Supporting software characteristics

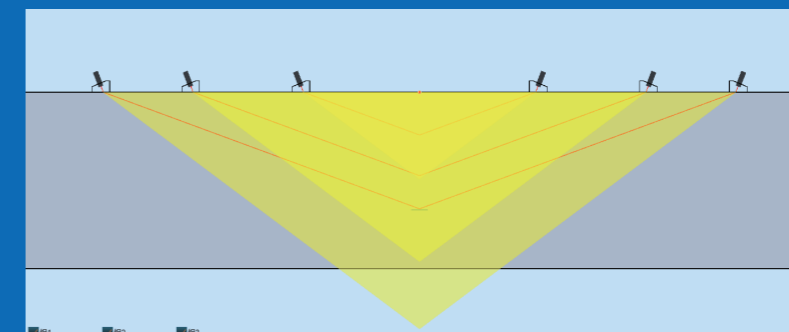

Multi-group TOFD coverage simulation

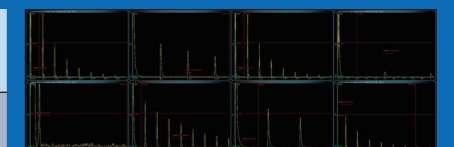

Multi-group UT channel data acquisition

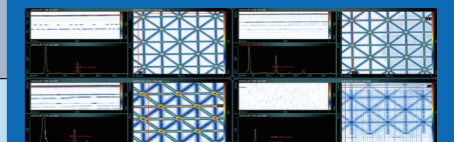

Multi-channel parallel scanning

Board Series

ROBUST S1 Single Channel Ultrasonic Board

Robust S1 single-channel ultrasonic board integrates excellent cost-effectiveness, excellent reliability, rapid integration ability and flexible expansibility, which can accurately meet the needs of basic detection, portable application and automation.

Core requirements in a variety of scenarios. This product is widely used in aerospace material testing, nondestructive testing of automobile parts, biomedical ultrasonic imaging and other application fields. Whether it is thickness measurement, defects Testing, or other ultrasonic testing applications, can provide accurate and reliable test results.

/01

General Interface

The interface has good universality and supports multiple common interface types. It can easily connect with external devices such as computers, sensors, and displays, enabling fast data transmission and sharing without the need for complex switching devices, saving time and costs.

/02

Wideband detection

It has broadband characteristics and can accurately acquire and process signals in a wider frequency range. Whether it is minor defects or complex material property analysis, it can present clear and reliable detection results to meet the detection needs of different scenarios.

/03

High voltage output

Up to 400V voltage output, providing powerful energy for ultrasonic testing. Even in the face of complex detection environments and difficult tasks, it can ensure that the ultrasonic signal has sufficient strength and penetration, improving detection sensitivity and reliability.



Easy to integrate
High degree of modularity



Less interference
Simple signal path



Simple structure Easy
maintenance and customization



Support single crystal
Dual crystal probe detection

Performance

Parameter	Parameter
Configuration	
Receive/Transmit	1/1
Velocity	340-15240m/s
Pulser	
Test Mode	PE / PC / TT / TOFD
Voltage	100V / 200V / 400V
Pulse Shape	Sharp pulse/Negative Square Wave
Pulse Width	20-1000ns,2.5ns
Rise Time	<8ns
PRF	40KHz
Receiver	
Gain	0-120dB
Bandwidth	1-34.5MHz
Data Acquisition	
Sampling Rate	200MHz
ADC	16bit
Maximum A-scan	16384
Rectification Mode	FW / HW+ / HW- / RF
Power Supply	
DC	15V DC

Parameter	Parameter
Scan/Display	
Display Mode	A / B / C / D / Band chart / FFT
Unit	mm / inch
TCG	
Point	32
Gain Range	40dB
Max Gain Slope	40dB/us
Gate	
Gate	A/B/C/I + Custom gate
Threshold	0-100%
Gate mode	Depth/sound path
I/O Port	
Ethernet	1000Mb/s
Encoder	Dual axis,LEMO 16-pin
Synchronous Interface	SMA
Case	
Size	120mm × 90mm× 40mm
Weight	0.4Kg

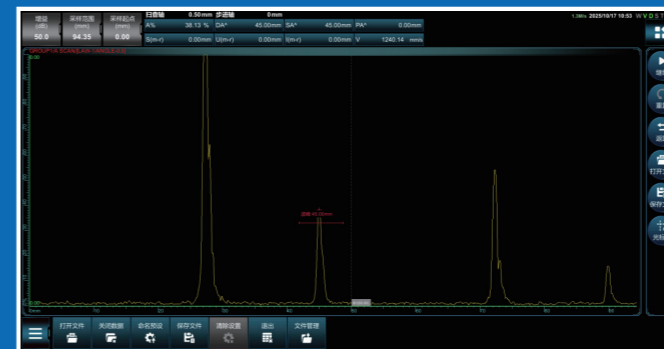

Accurate thickness measurement

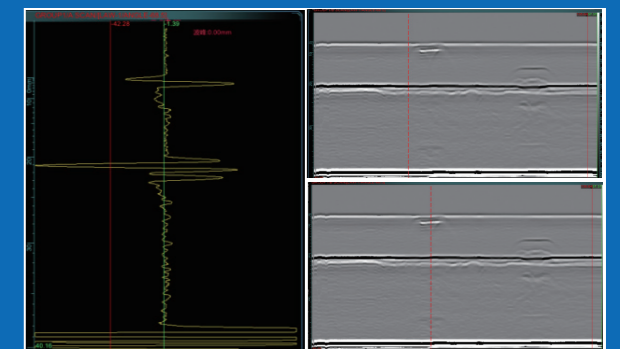

TOFD weld detection

Board Series

ROBUST F1 Phased Array Ultrasonic Board

/01

High-Performance Matrix Array Platform

High-speed processing chip · 64/64 · 128/128 · 256/256 versions · Optimized for matrix & MA probes · Ideal for nuclear, aerospace, rail & power industries · Suitable for thick, high-attenuation & dissimilar metal welds.

/03

3D TFM & Ultra-High Resolution

3D, FMC-TFM, PWI-TFM, FMC-PCI, PWI-PCI modes · Up to 4 million data points · High-resolution imaging for complex structures.

/02

Parallel Scanning & Ultra-Fast Acquisition

Parallel multi-element scanning · Multi-cycle excitation · Up to 40 kHz PRF · Real-time multi-channel processing.

/04

High-Energy Pulse & Multi-Tech Integration

Bipolar high-penetration pulse · PA-UT · PA-TOFD combination · Adaptable to diverse probes & harsh environments.



128/128

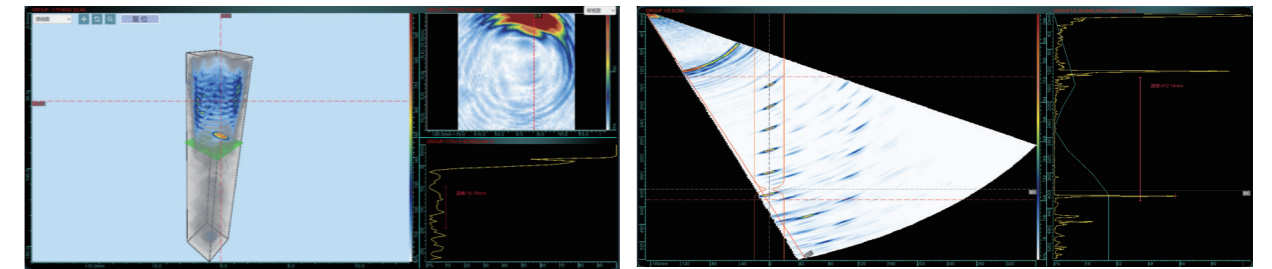

Bolt 3D TFM imaging

Weld detection of 400mm thick carbon steel material

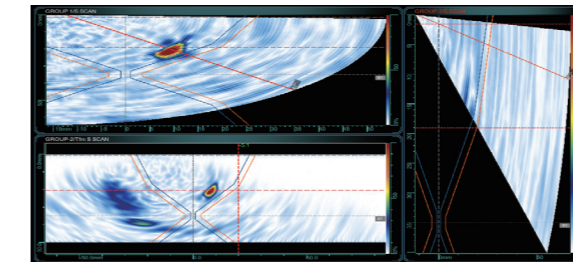

Detection of CRA weld test block

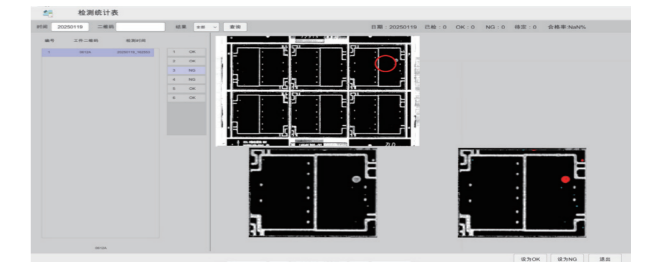

Intelligent defect identification

Performance

Parameter	Parameter
Configuration	
Receive/Transmit	256/256PR,128/128PR,64/64PR
Velocity	340-15240m/s
Pulser	
Test Mode	PE / PC
Voltage	40V/70V/100V/130V/150V/200V (256/256PR)
Pulse Shape	Bipolar square wave
Pulse Width	20-1000ns, 2.5ns
Rise Time	<8ns
PRF	40KHz
Delay	20µs/2.5ns
Receiver	
Gain	0-120dB
Bandwidth	0.4-25MHz
Delay	20µs/2.5ns
Data Acquisition	
Sampling Rate	200MHz
ADC	16bit
Maximum A-scan	16384
No.of Focal Laws	1024
Focus Type	True Depth/Sound Path/Projection/Focal Plane
Rectification Mode	FW/HW+/HW-/RF

Parameter	Parameter
Scan/Display	
Type	TFM/Linear/Sectorial/Compound scanning
Display Mode	A/B/S/C/FMC-TFM/PWI-TFM/3D/TOPC/Band chart
Unit	mm, inch
Language	
Language	Chinese/English/French/German/Russian/Italian
TCG	
Point	16
Gain Range	40dB
Band filter	
Band filter	Full time data averaging
Gate	
Gate	A/B/C/I + Custom gate
Threshold	0-100%
Gate trigger mode	Peak/leading edge
I/O Port	
Ethernet	1000Mb/s, 10Gb/s
Encoder	Dual axis, LEMO 16-pin
Physical specification	
Measure	390.03 × 243 × 227mm(256) 388.53 × 243 × 137mm(128) 266 × 216 × 65mm(64)
Weight	12.2Kg(256), 7Kg(128), 4Kg(64)

Board Series

ROBUST L1 Small Phased Array Ultrasonic Board

In the field of precision industrial testing, the miniaturization of equipment and cost-effectiveness are becoming new demands from users. In the fields of non-destructive testing in industries such as aerospace, energy and power, and rail transportation, the requirements for the portability and cost-effectiveness of testing equipment are higher in on-site operations and scenarios with limited space. The ROBUST L1 series (16/128 board cards) phased array ultrasonic testing system newly launched by Guangzhou Doppler is a high-performance, cost-effective solution that has emerged in response to this demand.

/01

Small size, carry with you

The ROBUST L1 series adopts a compact design, small size and light weight (about 1kg), which is very suitable for field inspection and system integration applications with limited space and easy to integrate and install.

Despite its compact size, its performance has not been compromised. It inherits the rugged and reliable characteristics of the Duola product line and can adapt to various demanding industrial environments, providing a solid foundation for the overall stability of the system.

/02

Comprehensive function and wide application

Although ROBUST L1 is positioned in a lighter and more economical market, its functions are still comprehensive. The board integrates three detection modes, namely PA, TFM and PWI, and can flexibly meet a variety of complex nondestructive testing requirements. Support A/B/S/C/TFM/TopC and combined display mode, and have full data encoder recording function.

This board provides support for all kinds of automatic phased array ultrasonic testing system platforms, and provides extended software and hardware interfaces to support secondary development. This leaves room for users' future function customization and system upgrade.

/03

Cost-effective choice, performance remains the same

ROBUST L1 series adopts 128-channel transmitting and 16-channel receiving hardware architecture. The cost is greatly reduced while ensuring high performance, and it still has excellent response ability in most conventional detection scenarios.

For enterprises or start-up teams with limited budget who want to adopt advanced phased array technology, L1 series provides an excellent entry and upgrade option.



Performance

Parameter	Parameter
Configuration	
Receive/Transmit	16/128
Velocity	340-15240m/s
Pulser	
Test Mode	PE / PC
Voltage	20V-100V / 10V
Pulse Shape	Negative Square Wave
Pulse Width	30-1000ns,2.5ns
Rise Time	<10ns
PRF	20KHz
Delay	20μs/2.5ns
Receiver	
Gain	0-120dB
Bandwidth	0.5-20MHz
Data Acquisition	
Sampling Rate	100MHz
ADC	12bit
Maximum Wave Height	200%
Maximum A-scan points	16384
Number of focusing rules	1024
Focus Type	True Depth/Sound Path/ Projection/Focal Plane
Detection	FW/HW+/HW-/RF
Power Supply	
DC	12V DC

Parameter	Parameter
Scan/Display	
Type	TFM/Linear/Sectorial/ Compound scanning
Display Mode	A/B/S/C/FMC-TFM/PWI-TFM/ TopC/Strip Chart
Unit	mm/inch
TCG	
Point	16
Gain Range	40dB
Max Gain Slope	40dB/ns
Gate	
Gate	A/B/C/I + Custom gate
Threshold	0-100%
Gate mode	Peak/Leading Edge
I/O Port	
Ethernet	1000Mb/s
Encoder	Dual axisDB15
Language	
Language	Chinese/English/Russian/ French/Italian/German
Case	
Size	152mm × 116mm × 87mm
Weight	1Kg

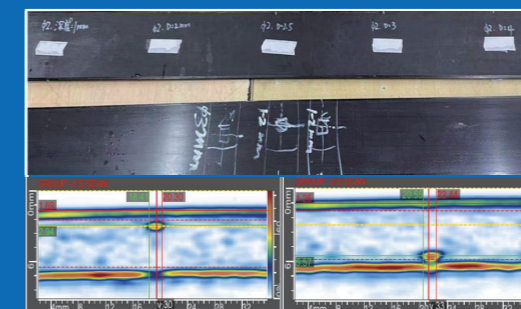

Carbon fiber pultruded board

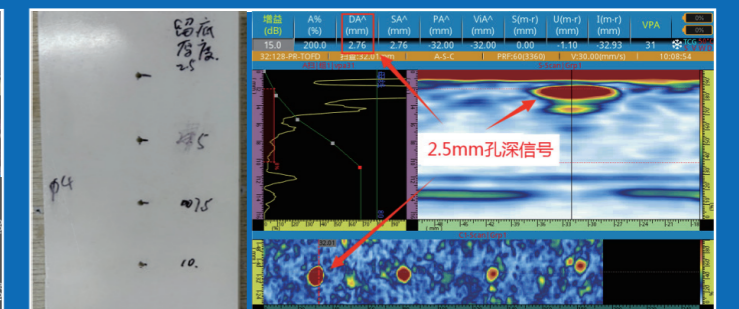

Glass fiber resin

Nexus F1 Pulser-Receiver

The Nexus F1 pulse transceiver is a new generation of high-performance ultrasonic pulse transmitting/ receiving products independently developed and produced by Doppler. It is specially built for high-frequency ultrasonic systems. Its core role is to provide key technical support for material defect detection by accurately controlling the transmission and echo resolution of ultrasonic signals.

/01

Features

- Compact, low-power design: Small size, easy integration.
- Dual modes: T/R echo (single probe) · Through-transmission (dual probe).
- Flexible filtering: Selectable high/low-pass filters.
- Broadband reception: 1-150 MHz adjustable bandwidth.
- High-speed operation: Up to 70 kHz PRF for automated lines.

Efficient and flexible, Nexus F1 is ideal for high-frequency ultrasonic testing applications.

Parameter comparison

Model/Parameters	Transceiver bandwidth (MHz)	Gain range (dB)	Minimum step (dB)	Max PRF (KHz)	Qualcomm filter (MHz)	low-pass filter (MHz)	Excitation time (ns)	Sampling rate (GHz)
Domestic type	1-150	-12~70	0.5	70	1/10	65/150	3.4	2
Imported type	5~300	-11~70	0.5	65	5/30	150/300	2.2	2



Performance

Parameter	Parameter
Receiver	
Detection mode	T/R echo · Through transmission
Bandwidth	1 ~ 150 MHz-12 ~ 70 dB
Gain range	1,10
High pass filter (MHz)	75,175
Low pass filter (MHz)	
Pulser	
Pulse Shape	Sharp pulse
Pulse falling edge	<3.4 ns
Voltage	150 V
PRF	70 KHz

Parameter	Parameter
I/O Port	
Communication interface	Mini USB 2.0
Trig trigger	SMA coaxial connector
Output output	SMA coaxial connector
Probe connector	SMA coaxial connector
Power Supply	
DC Supply Voltage	15V DC
Case	
Size	165.6mm×61.4mm×30.49mm
Weight	0.265 Kg

Application

As a high-precision, multi-scenario-adapted acoustic wave technology device, the application field of high-frequency ultrasonic pulse transceivers is extensive and constantly expanding, covering multiple directions such as industry, medicine, materials science, and bioengineering.

1. Industrial Inspection: Material Defect Identification and Precision Manufacturing
 - 3C industry: liquid-cooled radiator welding defects; titanium-aluminum alloy quality;
 - Microelectronic devices: ceramic capacitors, ceramic copper-clad plates, wafer internal cracks, and micro-scale imaging of chip package layering;
 - Evaluation of special materials and complex structures: debonding defects in turbine blade coatings, etc.
2. Medical field: high-resolution superficial imaging and treatment monitoring
3. Materials Science: Microstructural Characterization and Stress Analysis
 - Acoustic microscopy and nanoscale imaging: analysis of grain orientation and grain boundary stress.

Noise, receiver, transmit waveform performance

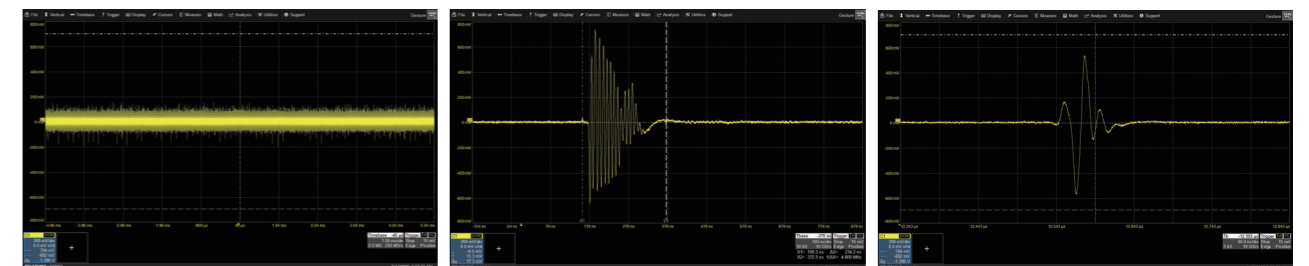

Maximum gain RF output noise

Initial wave width

50MHz probe, surface wave

Ultrasonic Inspection Applications

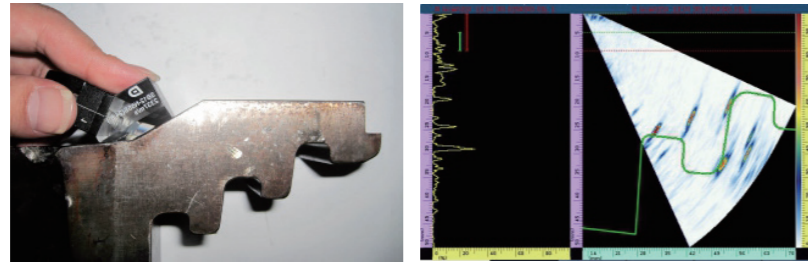

Straddle Type Turbine Root(Auto CAD Geometric)

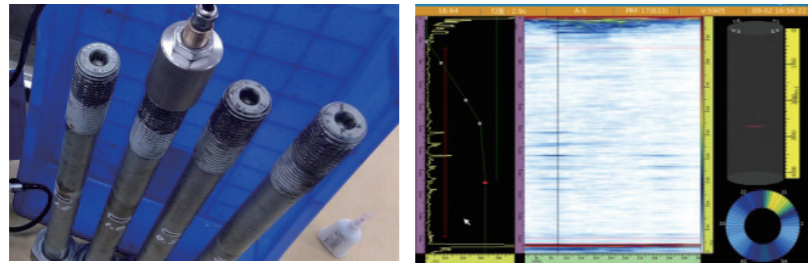

Wind Turbine Bolt Inspection(Cylindrical Guided Wave)

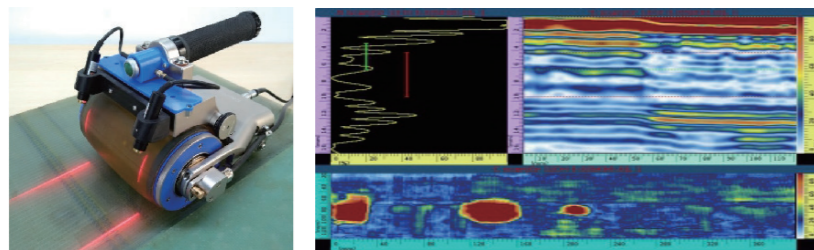

FPR Composite Wind Turbine Inspection

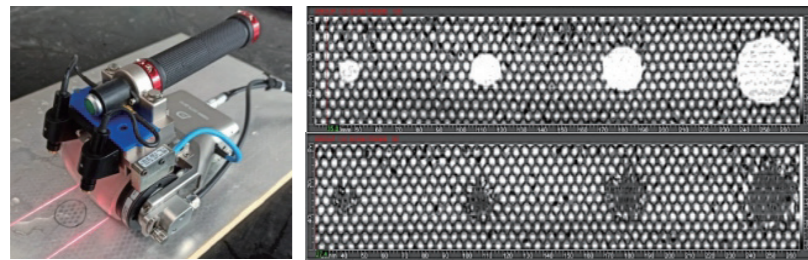

Inspection of Aviation Aluminum Honeycomb Panel

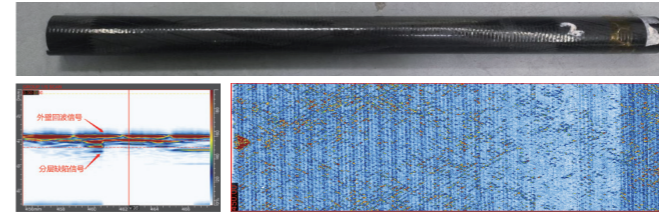

Carbon fiber pipe inspection

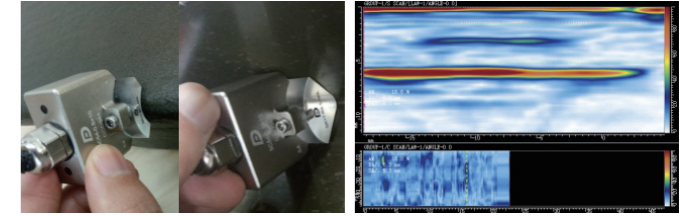

Aircraft CFRP Composite R Corner Inspection(Concave Probe)

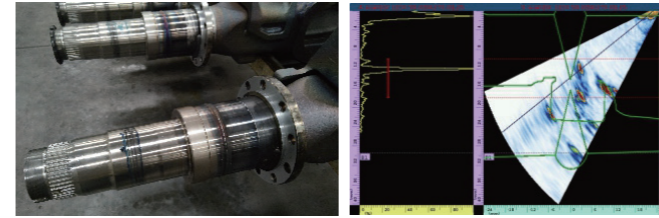

Electron Beam Welding(Auto CAD Geometric)

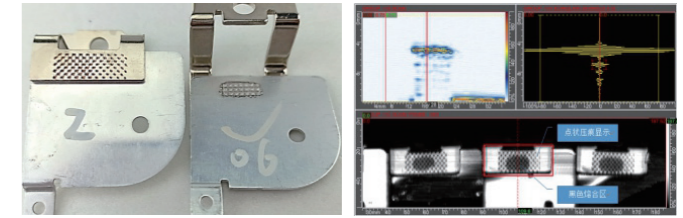

Quality Inspection of Vehicle Parts

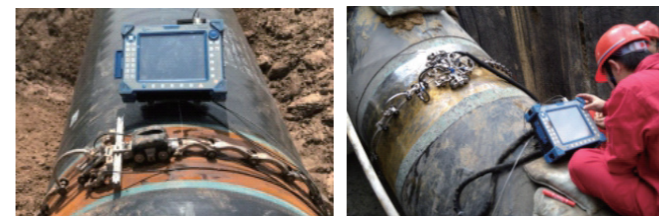

Circumferential Weld Inspection of Oil and Gas Pipelines

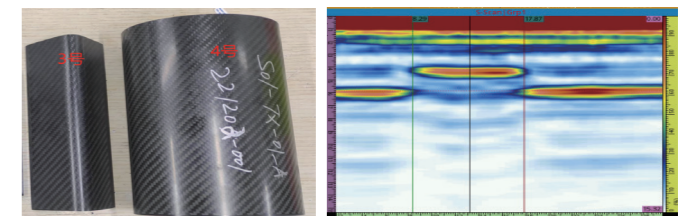

Ultrasonic detection of carbon fiber phased array for UAV arm

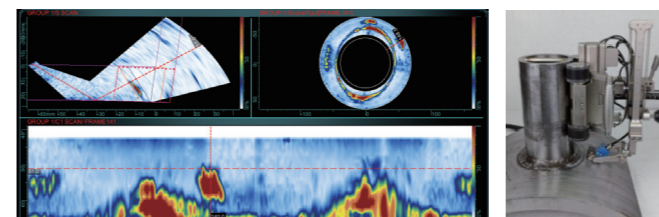

Inspection of fillet weld in tube socket (real-time update of Weld Section)

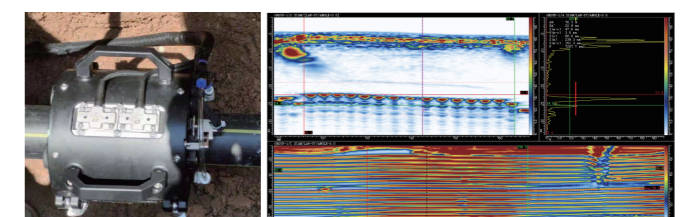

Inspection of PE electrofusion joint

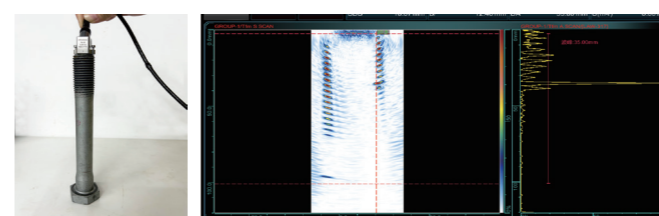

FMC-TFM inspection of bolt

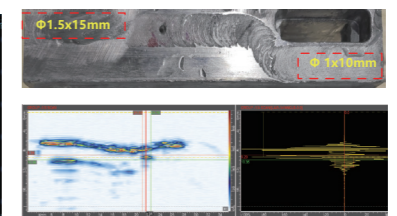

FSW friction stir welding inspection



Corrosion Inspection of Boiler Water Wall

02

INDUSTRIAL ARRAY PROBE

- Linear Array Probe Series
- Near-Wall Probe Series/Immersion Probe Series
- Laterally Focused Array Probe Series
- Immersion Probe Series/Matrix Array Probe Series
- Integrated Wedge Probe Series
- Water Bag Probe Series
- Soft Protective Film Probe Series
- Wheel Probe Series
- Flexible Probe Series
- High Temperature Probe Series
- R-Angle Probe Series
- Concave Array Probe Series
- Bolt Probe Series
- Spot Welding Probe Series
- Dual-Linear Array/Dual-Matrix/Wind Power Probe Series
- Other Special Probes
- Selection Of Industrial Array Probe
- Wedge
- Connectors & Adapters



Since its establishment in 2008, Doppler has designed and developed a wide range of ultrasonic industrial array probes with excellent performance and stable quality, and drafted JB/T 11731-2013 «General Technical Requirements for Ultrasonic Phased Array Probes for Nondestructive Testing» NB/T 47013.15-2021 «Nondestructive Testing of Pressure Equipment Part 15: Phased Array Ultrasonic Testing» and other related standards for phased array probes.



Ordering Instructions

The probe frequency of Doppler conventional ultrasonic industrial array is 0.5MHz-20MHz, the number of array elements is 8-1024, and the center distance between adjacent array elements is 0.15 mm-2.0 mm. Array categories include linear array, matrix, Self-focus, ring array, concave array, convex array, integrated wedge array, etc. Other types of probes can be customized according to customer requirements, and wedges, connector conversion boxes and extension lines can also be customized according to customer requirements.

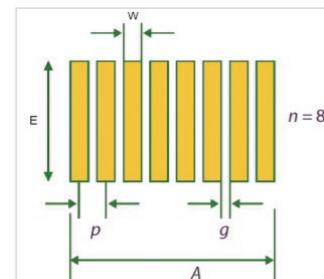
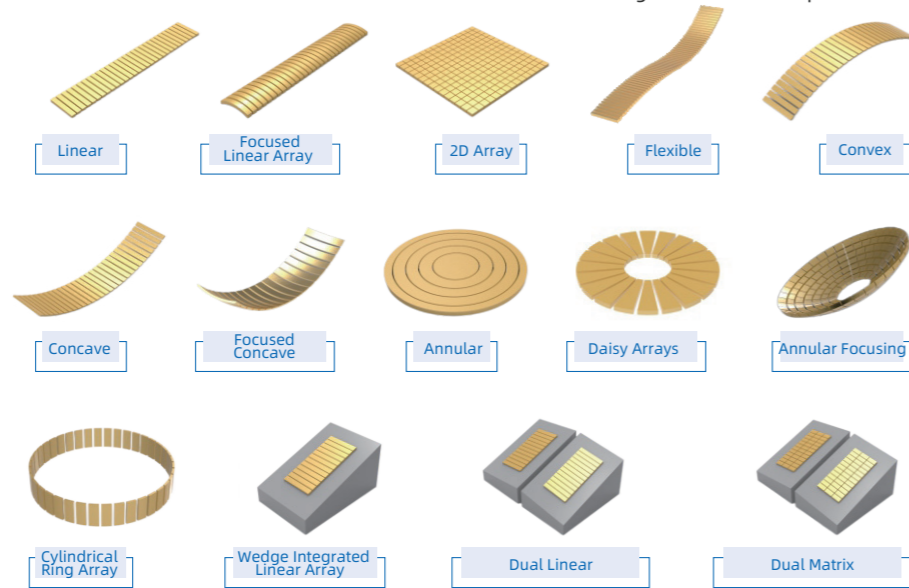

1D Probe parameters

A: Active aperture
E: Elevation
p: Elementary pitch
n: Number of elements in the PA probe
g: Internal element spacing
w: Element width
Active aperture: $A = n \times p$
Precise active aperture: $A = (n - 1) \times p + w$

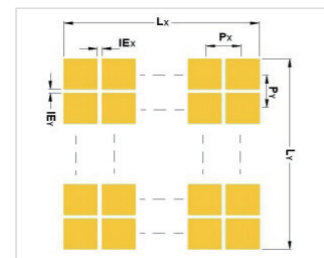

2D Probe parameters

Px: Primary Pitch
Py: Secondary Pitch
IEx: Primary Element spacing
IEy: Secondary Element spacing
Lx: Primary Aperture
Ly: Secondary Aperture



Custom Probe Description

We have a professional R&D technical team and a world-class ultrasonic transducer production line. We can customize transducers according to customer requirements.

To develop Self-defined transducers for customers, we need to know:

- Application scenarios, how to use existing probes;
- Probe's frequency, number of array elements, array element spacing, array element length, array configuration, probe type;
- Requirements such as size restrictions;
- Cable length and environmental requirements;
- Connector type and wire sequence requirements.



Probe Model Illustration

Frequency	1= 1 MHz 2.5= 2.5 MHz 5= 5 MHz 7.5= 7.5 MHz 10= 10 MHz 20= 20MHz		
Array Type	L(Linear) C(Concave) M(Matrix) S(Special)		
No.Elements	64= 64 Elements		
Pitch	0.6= 0.6mm		
Elevation	10= 10mm		
Probe Type	DP3= DP3 Series		
Cable Jacket Type	U= PU (Low smoke halogen-free)		
Cable Capacitance	110= 110pf/m 50= 50pf/m		
Cable Length	2.5=2.5m		
Connector Type	T1: QLC-260P	P1: I-PEX 30056	H1: Hypetronics
	D1: DL-156P	D2: DL-260P	D3: DL-96P
	M1: MOLEX 78P	J1: D38999/26FF35SN	C1: CONEC 78PIN

5 **L** **64** - **0.6** x **10** - **DP3** - **U** - **110** - **2.5** - **T1**

Frequency Array type No.Elements Pitch Elevation Probe Type Cable Jacket Type Cable capacitance Cable length Connector Type



Wedge Model Illustration

Wedge Type	Casing type matched to the wedge XX
Mounting Method	Angle between primary axis of probe and wedge N= Normal L= Lateral
Refraction Angle	0 = 0° 45 = 45° 55 = 55° 60 = 60°
Wave Type	S= Share Wave L= Longitudinal Wave
Auxiliary Use	I= Irrigation H= Scanner yoke attachment points C= Adjustable carbide wear pins P=Wear-resistant screw with hard plastic S=Stainless steel frame A=Limit groove.
Curvature Type	AOD= Axial outside diameter (circumferential scan) AID= Axial inner diameter (circumferential scan) COD= Circumferential outside diameter (axial scan) CID= Circumferential inner diameter (axial scan) SOD= Sphere outside diameter SID= Sphere inner diameter
Tube Diameter	203.2= 203.2mm
(HT)	High temperature wedge

S **DP3** - **N** **55** **S** - **IHC** - **AOD** **203.2** **(HT)**

Wedge type Mounting Method Refraction Angle Wave Type Auxiliary Use Curvature Type Tube Diameter High Temperature

Linear Array Series



Features

- Acoustically matched with Rexolite
- Linear array is the most widely used probe type in array probe at present. It can realize shear wave or longitudinal wave detection with wedge, and is widely used in the detection of base metal and weld seam of pipe fittings, forgings and flat plates.
- It can be used in aerospace, oil pipeline, automobile axle and other application scenarios, and special probes can be customized according to actual needs for special application scenarios.



Specifications and Dimensions

Model	Frequency (MHz)	Elements	Pitch(mm)	Active Aperture (mm)	Elevation (mm)	Long (mm)	Width (mm)	Height (mm)	Case Type
10L16-0.2x5	10	16	0.2	3.2	5	6	8	23	DP40
10L16-0.31x5	10	16	0.31	4.96	5	8	8	21	DP30
5L16-0.6x10	5	16	0.6						
7.5L16-0.6x10	7.5	16	0.6	9.6	10	13.4	28.5	20	DP1
7.5L32-0.3x10	5	32	0.3						
10L32-0.3x10	10								
5L32-0.6x10	5								
7.5L32-0.6x10	7.5	32	0.6	19.2	10	23	28.5	23	DP2
10L32-0.6x10	10								
2.25L32-0.75x24	2.25	32	0.75	24	24	29.5	42.5	25	DP4
5L32-0.8x10	5	32	0.8	25.6	10	29.5	28.5	23	DP31
2.25L32-1.0x10	2.25	32	1	32	10	36	28.5	23	DP28
5L32-1.0x10	5	64	0.5						
5L64-0.5x10	5	64	0.6	38.4	10	42.5	28.5	23	DP3
5L64-0.6x10	7.5	64	0.6						
7.5L64-0.6x10	7.5								
2.25L64-1.0x10	2.25								
5L64-1.0x10	5	64	1.0	64	10	70	28.5	23	DP5
7.5L64-1.0x10	7.5								
5L128-1.0x10	5	128	1.0	128	10	135	29.5	30	DP6

Near-wall Probe Series

(The distance from the edge of the first element and the edge of the last element to the outside of the housing is 1 mm)



Features

- Acoustically matched with Rexolite
- There are smaller blind spots at both ends.
- C-scan imaging combined with encoder is very suitable for detecting delamination, debonding and porosity of composites.



Specifications and Dimensions

Model	Frequency (MHz)	Elements	Pitch(mm)	Active Aperture (mm)	Elevation (mm)	Long (mm)	Width (mm)	Height (mm)	Case Type
7.5L32-0.5x7	7.5	32	0.5	16	7	18	18	20	DP44
5L32-1.0x7	5	32	1.0	32	7	34	19	25	DP55
5L64-1.0x7	5	64	1.0	64	7	66	19	20	DP22
5L128-1.0x7	5	128	1.0	128	7	130	21	35	DP33

Water Immersion Probe Series (Linear array)



Features

- Acoustic impedance matching water
- The shell material is corrosion-resistant stainless steel.
- It has waterproof performance within 1m underwater.
- Combined with automation system, online detection can be carried out.



Specifications and Dimensions

Model	Frequency (MHz)	Elements	Pitch(mm)	Active Aperture (mm)	Elevation (mm)	Long (mm)	Width (mm)	Height (mm)	Case Type
20L64-0.4x5	20	64	0.4	25.6	5	32	11	20	DP19
5L64-1.0x7	5	64	1.0	64	7	75	19	30	DP18
7.5L64-1.0x7	7.5	64	1.0	64	7	75	19	30	DP18
5L128-0.8x10	5	128	0.8	102.4	10	114	22	30	DP20
7.5L128-0.8x10	7.5	128	0.8	102.4	10	114	22	30	DP20

02

INDUSTRIAL
ARRAY
PROBE

Laterally Focused Array Probe Series



Features

- ✓ Acoustically matched with Rexolite
- ✓ The array element is bent in the length direction, and the sound beam is focused on the secondary axis, so that the sound field focus is greatly reduced and the energy is more concentrated, thus providing higher fine defect detection ability.
- ✓ DP8 series or DP38 series probes with Doppler Cobra scanning device and wedge can be used for automatic or semi-automatic inspection of pipelines with an external diameter of 20 mm ~ 115 mm.

Specifications and Dimensions

Model	Frequency (MHz)	Elements	Pitch(mm)	Active Aperture (mm)	Elevation (mm)	Physical focusing radius(mm)	Long (mm)	Width (mm)	Height (mm)	Case Type
5S16-0.5x10	5	16	0.5							
7.5S16-0.5x10	7.5			8	10	R35	24.64	22	10	DP8
7.5S32-0.25x10	7.5	32	0.25							
10S32-0.25x10	10			8	8	R20	24.76	22	11	DP38
10S32-0.25x8	10	32	0.25							
2S16-0.5x10	2	16	0.5	8	10	R80	25	22	14	DP9
2.5S16-0.5x10	2.5			8	10	R80	25	22	14	DP9
5S32-0.6x10	5	32	0.6	19.2	10	R80	23	28.5	23	DP29
7.5S32-0.6x10	7.5			19.2	10	R80	23	28.5	23	DP29
5S64-0.6x10	5	64	0.6	38.4	10	R35	42.5	28.5	24.5	DP7
7.5S64-0.6x10	7.5			38.4	10	R35	42.5	28.5	24.5	DP7
10S64-0.6x10	10			38.4	10	R35	42.5	28.5	24.5	DP7

Immersion Probe Series (Self-focusing linear array)

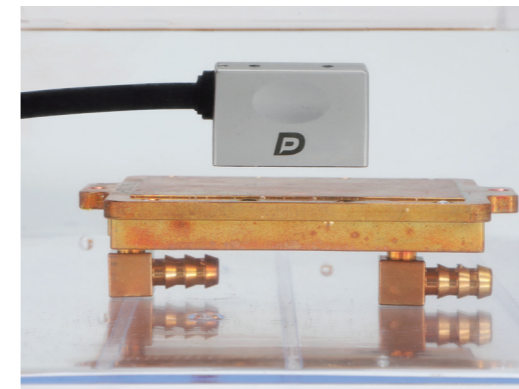

Features

- ✓ Acoustic impedance matching water
- ✓ The array element is bent in the length direction, and the sound beam is focused on the secondary axis, so that the sound field focus is greatly reduced and the energy is more concentrated, thus providing higher fine defect detection ability.
- ✓ The shell material is corrosion-resistant stainless steel.
- ✓ It has waterproof performance within 1m underwater.
- ✓ Combined with automation system, online detection can be carried out.

Specifications and Dimensions

Model	Frequency (MHz)	Elements	Pitch(mm)	Active Aperture (mm)	Elevation (mm)	Physical focusing radius(mm)	Long (mm)	Width (mm)	Height (mm)	Case Type
18S64-0.2x5	18	64	0.2	12.8	5	R35	22	12	26.48	DP48
20S128-0.2x5	20	128	0.2	25.6	5	R35	35	14	26.66	DP49
15S64-0.6x10	15	64	0.6	38.4	10	R35	43	16	26.87	DP50
15S128-0.6x10	15	128	0.6	76.8	10	R35	83	17	26.99	DP51

Matrix Array Probe Series



Features

- ✓ Acoustically matched with Rexolite
- ✓ Can be used for three-dimensional imaging.
- ✓ Both the primary and secondary acoustic beams can be deflected, with smaller spatial focus, more concentrated energy and better signal-to-noise ratio.

Specifications and Dimensions

Model	Frequency (MHz)	Elements	Pitch Px (mm)	Pitch Py (mm)	Active Aperture Lx (mm)	Active Aperture Ly (mm)	Long (mm)	Width (mm)	Height (mm)	Case Type
5M8x8-1.0x1.0	5									
7.5M8x8-1.0x1.0	7.5	64 (Primary8/Secondary 8)	1.0	1.0	8	8	21	13	28	DP15
10M8x8-1.0x1.0	10									
5M16x8-1.5x1.5	5	128 (Primary16/Secondary 8)	1.5	1.5	24	12	30	28	35	DP35
10M16x8-1.5x1.5	10									

02

INDUSTRIAL
ARRAY
PROBE

Integrated Wedge Probe Series



Features

- ✓ The wafer and wedge are permanently fixed, and there is no need to add coupling agent between them during testing.
- ✓ The wedge is built in, and the overall size of the probe is smaller, which is convenient for detection in a narrow space.
- ✓ Direct contact scanning with angle is possible.
- ✓ The probe with built-in wedge can be customized according to actual requirements (including making copying coupling surface to adapt to specific curved workpiece).

Specifications and Dimensions

Model	Frequency (MHz)	Elements	Pitch(mm)	Active Aperture (mm)	Elevation (mm)	Refract angle	Long (mm)	Width (mm)	Height (mm)	Case Type
5L12-0.5x6	5	12	0.5	6	6	55° SW (Steel)	24.87	13	10.35	DP16
5L12-0.5x6	5	12	0.5	6	6	45° SW (Aluminum)	25	9	10.42	DP36
5L12-0.5x6	5	12	0.5	6	6	45° LW (Aluminum)	28	9	12	DP46
4L16-0.5x9	4	16	0.5	8	9	58° SW (Steel)	27	16.56	22	DP45

Water Bag Probe Series



Features

- ✓ With the use of water bag wedge, the special structure design reduces the influence of clutter compared with the conventional wedge.
- ✓ The bottom of the water bag wedge is a replaceable flexible coupling surface, which can be used to detect irregular curved workpieces without surface damage during the detection process.
- ✓ Combined with Doppler scanner and water bag wedge, it can be used to detect the electrofusion butt joint of PE pipe.

Specifications and Dimensions

Model	Frequency (MHz)	Elements	Pitch(mm)	Active Aperture (mm)	Elevation (mm)	Long (mm)	Width (mm)	Height (mm)	Case Type
4L64-0.8x10	4	64	0.8	51.2	10	66	35	25	C45
2.5L64-1.0x7	2.5	64	1.0	64	7	79	35	35	Z63
5L128-0.6x10	5	128	0.6	76.8	10	94	36	25	WD94
4L128-0.8x10	4	128	0.8	102.4	10	120	36	25	WD83

Soft Protective Film Probe Series



Features

- ✓ The front end is a replaceable soft protective film and a fixed sleeve, which not only prolongs the service life of the probe, but also provides reliable coupling to rough surfaces.
- ✓ Ergonomic shell design is adopted, with 0° longitudinal wave incidence, which supports the detection of thick workpieces (such as castings, forgings, solid shafts, etc.) and can cover+30° to-30° S-scan.

Specifications and Dimensions

Model	Frequency (MHz)	Elements	Pitch(mm)	Active Aperture (mm)	Elevation (mm)	Diameter (mm)	Height (mm)	Case Type
2L16-1.0x16	2	16	1.0	16	16	Φ46	59	DP25
4L16-1.0x16	4	16	1.0	16	16	Φ46	59	DP25
2.25L32-0.5x16	2.25	32	0.5	16	16	Φ46	59	DP25

Wheel Probe Series



Features

- ✓ With its own water storage coupling system and encoder, the coupling effect is good and efficient C-scan imaging can be carried out.
- ✓ Using tire materials with extremely low attenuation
- ✓ Optional with angle adjustment block, the angle of incidence of the probe can be adjusted from 0° to 20°.
- ✓ With automatic scanning device, it can be suitable for large-area plane or micro-surface detection.

Specifications and Dimensions

Model	Frequency (MHz)	Elements	Pitch(mm)	Active Aperture (mm)	Elevation (mm)	Long (mm)	Width (mm)	Height (mm)	Case Type
5L64-0.8x6.4	5	64	0.8	51.2	6.4	128	25	25	E96
7.5L64-0.8x6.4	7.5	64	0.8	51.2	6.4	128	25	25	E96
10L64-0.8x6.4	10	64	0.8	51.2	6.4	128	25	25	E96
1L64-1.5x22	1	64	1.5	96	22	166	40	40	G79
1L128-1.0x22	1	128	1.0	128	22	210	42	42	MY88
2.25L128-1.0x22	2.25	128	1.0	128	22	210	42	42	MY88

02

INDUSTRIAL
ARRAY
PROBE

Flexible Probe Series



Features

- ✓ The principal axis direction can bend with the shape of the workpiece surface, and the curvature is variable, with a minimum bending radius of 30 mm.
- ✓ The minimum thickness of the flexible part is 3mm, which can be detected in a narrow space.
- ✓ Combined with Doppler scanning device, it can detect corrosion or thickness of pipes and bars with different sizes.

Specifications and Dimensions

Model	Frequency (MHz)	Elements	Pitch(mm)	Active Aperture (mm)	Elevation (mm)	Long (mm)	Width (mm)	Height (mm)	Case Type
5S64-0.5x10	5	64	0.5	32	10	80	19	4	DP26
7.5S64-0.5x10	7.5	64	0.5	32	10	80	19	4	DP26
5S64-1.0x10	5	64	1.0	64	10	150	29	4	DP27
7.5S64-1.0x10	7.5	64	1.0	64	10	150	29	4	DP27

High Temperature Probe Series

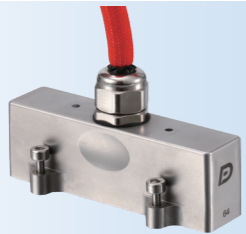

Features

- ✓ The probe is temperature-resistant, matched with Doppler high-temperature wedge, and can continuously detect on the workpiece with surface temperature of 150°C without cooling.
- ✓ Matching can be used as 0 degree longitudinal wave or high temperature wedge with angle.



Features

- ✓ The upgraded and iterative second-generation high-temperature probe, combined with the Doppler high-temperature wedge, can work under the working conditions of 350°C workpiece surface temperature for a long time

Specifications and Dimensions

Model	Frequency (MHz)	Elements	Pitch (mm)	Active Aperture (mm)	Elevation (mm)	Long (mm)	Width (mm)	Height (mm)	Case Type	High-temperature type
2.25L32-1.0x10	2.25	32	1.0	32	10	36	28.5	23	DP28	HT (150°C)
5L32-1.0x10	5	32	1.0	32	10	36	28.5	23	DP28	
5L64-1.0x10	5	64	1.0	64	10	70	28.5	23	DP5	
5L32-0.6x10	5	32	0.6	19.2	10	28.5	23	23	MD2	HEHT (350°C)

R-angle Probe Series



Features

- ✓ Acoustically matched with Rexolite
- ✓ It can be used to detect the fillet of composite materials, and a single scan can cover the whole fillet area.
- ✓ The acoustic beams of all elements are incident on the rounded surface at an angle of 90°, and the incident mode is similar to that of plane detection.
- ✓ With different wedges, it can be detected from both the inside and the outside of the fillet.

Specifications and Dimensions

Model	Frequency (MHz)	Elements	Pitch (mm)	Active Aperture (mm)	Elevation (mm)	Radius (mm)	Long (mm)	Width (mm)	Height (mm)	Case Type
7.5C32-0.5x10	7.5	32	0.5	16	10	11	28	30	25	DP23
5C32-1.47x10	5	32	1.47	16	10	11	28	30	25	DP23
5C64-0.735x10	5	64	0.735	47.04	10	30	70.18	30	35.52	DP39
10C64-0.735x10	10	64	0.735	47.04	10	30	70.18	30	35.52	DP39

Concave Array Probe Series



Features

- ✓ Acoustic impedance matching water
- ✓ The shell material is corrosion-resistant stainless steel.
- ✓ It has waterproof performance within 1m underwater.
- ✓ Combined with automation system, online detection can be carried out.
- ✓ With Doppler scanning device, corrosion and thickness measurement of pipes and bars with different sizes can be automatically or semi-automatically detected.

Specifications and Dimensions

Model	Frequency (MHz)	Elements	Pitch (mm)	Active Aperture (mm)	Elevation (mm)	Radius (mm)	Long (mm)	Width (mm)	Height (mm)	Case Type
10C128-0.6x9	10	128	0.6	76.8	9	40	94	20	60	DP43
5C128-0.95x12	5	128	0.95	121.6	12	50	120	23	70	DP24

02

INDUSTRIAL
ARRAY
PROBE

✓ Bolt Probe Series



Features

- ✓ In-service inspection can be carried out on the bolts in working state without disassembly, which greatly shortens the maintenance time.
- ✓ High detection accuracy and efficiency, and the whole defect detection of bolts can be completed by single coupling.
- ✓ It is suitable for detecting bolt defects in different fields such as bridges, high-speed rail and wind power.
- ✓ Suitable for M20~M100 bolt inspection.

Specifications and Dimensions

Model	Frequency (MHz)	Elements	Pitch(mm)	Inner Diameter(mm)	Outer Diameter(mm)	Bolt Diameter(mm)	Diameter (mm)	Height (mm)	Case Type
5S64(Φ15-Φ8)	5	64	0.56	8	15	M20	22	25	DP37
5S64(Φ29-Φ18)	5	64	1.15	18	29	M36	35	25	DP17
5S64(Φ42-Φ30)	5	64	1.77	30	42	M48	47	25	DP47

✓ Spot Welding Probe Series



Features

- ✓ Acoustically matched with Rexolite
- ✓ The probe is in spontaneous and self-collecting mode, which can obtain the surface and internal information of the workpiece and understand the welding situation covering the solder joint area.
- ✓ The front end is a replaceable delay block and a fixed sleeve, which can not only prolong the service life of the probe, but also eliminate the near-field blind zone of ultrasonic wave.
- ✓ Suitable for resistance spot welding and other welding spot detection.

Specifications and Dimensions

Model	Frequency (MHz)	Elements	Pitch Px(mm)	Pitch Py(mm)	Active Aperture Lx(mm)	Active Aperture Ly(mm)	Long (mm)	Width (mm)	Height (mm)	Case Type
15M8x8-1.0x1.0	15	64(Primary8/Secondary8)	1.0	1.0	8	8	24	20	30	DP41
15M8x8-1.5x1.5	15	64(Primary8/Secondary8)	1.5	1.5	12	12	26.5	25	30	DP42

✓ Dual-Linear Array/Dual Matrix Probe Series

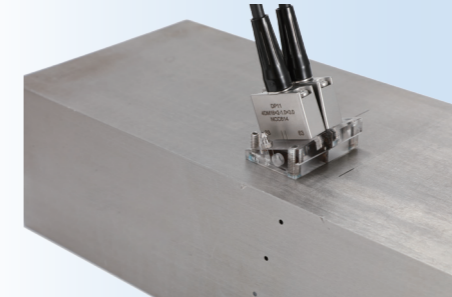

Features

- ✓ Acoustically matched with Rexolite
- ✓ The probe is in the mode of sending and receiving, and has a very small surface blind area, which greatly optimizes the surface resolution of the workpiece to be measured.
- ✓ Compared with conventional dual-crystal UT probe, this series of probes has larger coverage, better imaging effect and better signal-to-noise ratio.
- ✓ Suitable for welding seam detection of austenitic materials and dissimilar materials.

Specifications and Dimensions

Model	Frequency (MHz)	Elements	Pitch Px(mm)	Pitch Py(mm)	Active Aperture Lx(mm)	Active Aperture Ly(mm)	Long (mm)	Width (mm)	Height (mm)	Case Type
5DL16-0.75x5	5	32 (Dual linear array)	0.75	/	12	5	24	23.6	19.72	DP12
10DL32-0.375x5	10	32 (Linear array) /64 (Dual linear array)	0.375	/	12	5	24	23.6	19.72	DP12
2.25DL32-0.6x12	2.25	32 (Linear array) /64 (Dual linear array)	0.6	/	19.2	12	33.8	17	25	DP13
4DL32-1.0x10	4	32 (Linear array) /64 (Dual linear array)	1.0	/	32	10	46	16	20	DP14
2.25DL64-1.0x12	2.25	64 (Linear array) /128 (Dual linear array)	1.0	/	64	12	80.2	16.5	25	DP34
2.25DM7x4-2.71x3.0	2.25	28 (Matrix array) /56 (Dual Matrix array)	2.71	3.0	18.97	12	33.8	16	20	DP10
4DM16x2-1.0x3.0	4	32 (Matrix array) /64 (Dual Matrix array)	1.0	3.0	16	6	28.5	10	20	DP11

✓ Wind Power Probe Series

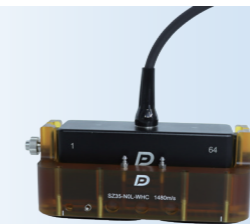

Features

- ✓ Acoustic impedance matching water
- ✓ The special water wedge can be used to detect the adhesion of wind turbine blades.
- ✓ Suitable for detecting workpieces with high attenuation and thick materials.

Specifications and Dimensions

Model	Frequency (MHz)	Elements	Pitch(mm)	Active Aperture (mm)	Elevation (mm)	Long (mm)	Width (mm)	Height (mm)	Case Type
0.5L64-1.5x22	0.5	64	1.5	96	22	120	34	50	Z35
1L64-1.5x22	1	64	1.5	96	22	120	34	50	Z35

02

INDUSTRIAL
ARRAY
PROBE

Other Special Probes

According to the needs of on-site detection, we can develop special customized probes for customers. Some customized probes are listed below. Doppler is your best choice for solutions for difficult scenes.



Multi circular sector probe

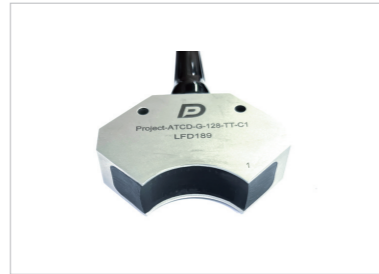

Self-focusing concave array probe



Annular taper probe



Multi connector probe



Inner-through annular self focusing convex array probe



Inner-through annular convex array probe



Inner-through annular convex matrix probe

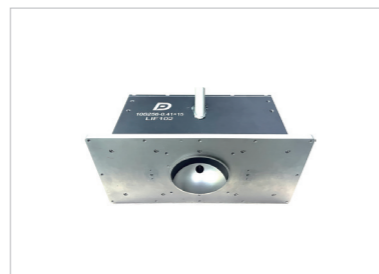

Integrated self-focusing concave probe



Circular array probe



Annular hollow focusing probe

Selection Of Industrial Array Probe



- The corrugated sleeve can protect the cable from corrosion and external impact
- Nylon mesh sleeve can increase protection while maintaining the flexibility of cable
- Metal corrugated tube can enhance shielding and anti-interference on the basis of protecting cable lines from corrosion and impact resistance

High sound transmission soft protective film can be directly pasted on the surface of phased array probe, so that the 0° wedge is not needed for detection, the interference caused by multiple echoes on the lower surface of the wedge is effectively eliminated, and the detection cost is effectively reduced

Instructions for Phased Array Probe

- A layer of blue protective film is pasted on the probe surface to avoid scratches during transportation. Please tear off the protective film before use, otherwise it will affect the performance of the probe
- Do not forcibly plug and unplug the connector to avoid pin damage
- Use the probe carefully to avoid impact by external force
- When the probe is not in use, it shall be sealed and stored, such as in the original suitcase, so as not to be affected by environment
- The application scenarios of different types of probes are determined according to the specific application standards. The solutions of different scenarios are welcome to inquire. Website: www.cndoppler.com, Email: cndoppler@cndoppler.cn

Warranty Description

The warranty period of Doppler phased array probe is generally one year, and the warranty scope does not include damage or wear caused by misuse or accident, such as:

- Incorrect assembly method
- Incorrect use, including but not limited to the impact of the probe surface, unauthorized disassembly, etc.
- For use in an environment outside the allowable range, the storage temperature range of the probe is generally -30°C to 50°C, and the service temperature range is -20°C to 50°C
- The excitation voltage is too large. Generally, the maximum repetition frequency is 10 KHz, and the continuous operation is no more than 5 KHz 100V (the details shall be subject to the probe test report)
- Use of substandard couplant

General Index of Phased Array Probe

Doppler has strict quality standards for products, and the general indicators of products are as follows (according to JB / T 11731-2013 test standard):

Sensitivity conformity	±2dB
Sensitivity difference between batches	±2dB
Service temperature	-20°C to 50°C
Storage temperature	-30°C to 50°C

02

INDUSTRIAL
ARRAY
PROBE

Wedge

Features

- ✓ Generally, it is used for SW or LW detection with an angle between 30 ° and 70 °, providing refraction angles in standard steel such as 0 °, 45 °, 55 ° and 60 °
- ✓ Composite anti-wear screws can be used on easily scratched surfaces
- ✓ High temperature wedge is used in high temperature environment and can withstand high temperature of 260 °C
- ✓ Wedge shape and parameters can be customized according to customer requirements



Anti Wear Wedge



Water Wedge



Angle Wedge



Dual Array Wedge



0° Wedge



High Temperature Wedge

Specifications and Dimensions

Wedge Type	Wedge Mode	Probe Type	Refraction Angle	Wedge Dimensions			Wedge Angle
				Long(L)mm	Width(W)mm	Height(H)mm	
0°Wedge	SDP3-N0L-H	DP3	0°LW	48	30	20	0°
Angle Wedge	SDP2-N55S-IH	DP2	55°SW	41	30	26.64	36°
Anti Wear Wedge	SDP2-N55S-IHC-AOD326	DP2	55°SW	41	30	27.29	Φ326mm
Dual array Wedge	SDP11-N55L-IHC (TR, roofangle3.7°, F=15)	DP11	55°LW	30	40	14.96	18.7°
High temperature Wedge	SDP28-N55S-IH(HT)	DP28	55°SW	64	44	34	39.5°
Water Wedge	SDP8-N65L-IH-AOD270	DP8	65°LW	23.96	22	13.12	Φ270mm

Connectors

Doppler provides compatible connectors for all kinds of Phased Array Probes in the market, such as T1, P1, J1, H1, P1(Quick lock), D2, D3, M1, etc.



T1: QLC-260P



P1: I-PEX 30056



J1: D38999/26FF35SN



P1(Quick lock)



D2: DL-260P



H1: Hypertronic

Adapters

The Doppler phased array ultrasound probe connector adapter box can be arbitrarily switched between T1, P1, J1, H1, D1, D2, D3, M1 and other interfaces, and can be customized according to customer requirements.



T1(Male)-J1(Female)
J1(Probe)-T1(Instrument)



T1(Male)-P1(Female)
P1(Probe)-T1(Instrument)

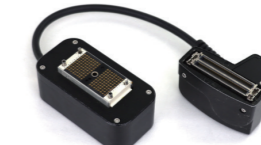

T1(Male)-H1(Female)
H1(Probe)-T1(Instrument)

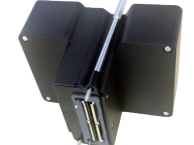

P1(Male)-T1(Female)
Integrated Adapter Box



P1(Quick lock/Male)
-4P1(Female)



T1(Male)
-5J1(Female)



T1(Male)
-4P1/40Lemo(Female)



P1(Male)
-128Lemo(Female)

03

SCANNER PRODUCT



- Corrosion and Base Material Inspection
- Weld Inspection
- Encoder
- PE Pipe Butt Joint Inspection

The scanner product is an essential component of ultrasonic testing and serves as the foundation for manual to semi-automatic and automated inspection. The scanner is typically capable of holding multiple probes, making it suitable for complex inspection scenarios that require multiple probes, greatly improving testing efficiency. In addition, the scanner is generally equipped with a position encoder, which helps to achieve full data recording, providing convenience for data archiving and subsequent analysis.

Corrosion and Base Material Inspection

Manual Chain Type for Piping

MOS08 Chain-Type Axial Stepping Scanner

The MOS08 quick-release chain-link pipeline weld scanner is an efficient, flexible, and professional inspection tool that provides a highly reliable and adaptable pipeline inspection solution for industrial applications. It is the ideal choice for those seeking high-efficiency and high-precision pipeline inspections.

Product Introduction

Flexible Quick-Release Design

The MOS08 features an innovative quick-release chain-link design, making switching between different pipe diameters quick and easy. It can accommodate a minimum pipe diameter of 100mm, meeting the needs of small pipeline inspections.

Stepping Axis Function

The scanner's unique stepping axis allows for precise positioning during the inspection process. When performing pipeline corrosion detection, the stepping function ensures continuous and uniform scanning, guaranteeing the continuity and accuracy of the inspection process.

Customizable Stroke

The stepping axis provides a stroke range of 250mm and can be customized according to the specific requirements of the customer.

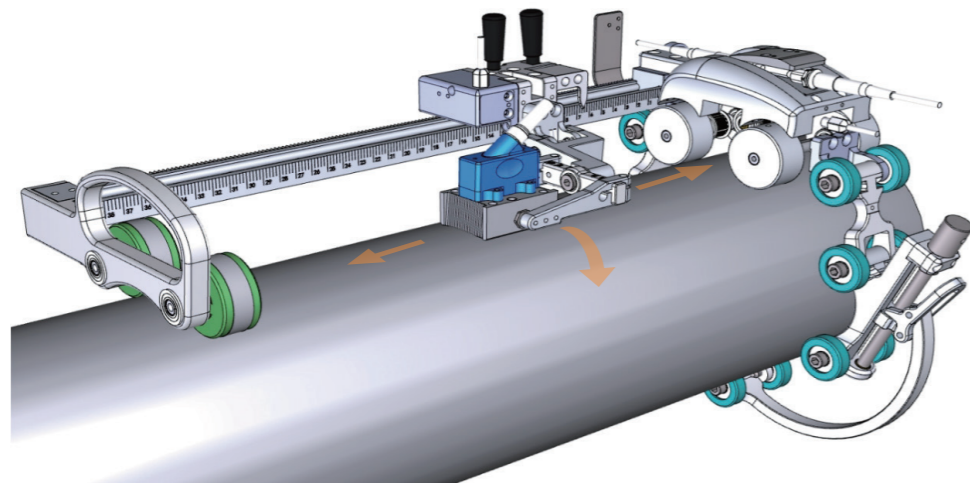

Manual/Flat Probe Water-Filled Type

DSC06 Corrosion Scanner



DSC06 is a scanner specially designed for corrosion detection of pipes and flat workpieces. It adopts local water immersion detection method and comes standard with a 64-element phased array probe. If you need other specifications of water layers or probes with different array elements, we can provide customized services. The scanning device is compact in design, easy to carry and operate, and greatly improves the convenience of field operation. The standard configuration is suitable for pipes and flat plates with a diameter of more than 60 mm.

Manual/Curved Probe Water-Filled Type

FS04 Axial Straight Pipe Flexible Probe Scanner



The FS04 scanning device is specifically designed for axial corrosion inspection of straight pipes. It consists of magnetic adsorption wheels, a support frame, a water jacket, an encoder, and a flexible probe. For pipes of different diameters, the device can be adapted to pipes with diameters greater than 38mm by replacing the water jacket.

FS06 Elbow Scanner



The FS06 scanner is an efficient product designed for inspecting corrosion in both bent and straight pipes. It consists of the following key components

- Flexible Probe
A single probe can be used for multiple pipe diameters.
 - Guiding Support Wheels
These ensure the probe smoothly passes through the pipeline
 - Water Jacket
Customizable according to different pipe diameters, ensuring correct probe positioning and protecting the pipe surface.
 - Encoder
Provides precise location information.
- This scanner is particularly suited for elbow pipe inspection and can accommodate pipes with a minimum diameter of 102mm. Users can interact with the scanner via buttons to control line switching and start the inspection, ensuring an efficient operational process.

Manual/Wheel-Type Probe Scanner

LS03 Wheel-Type Scanner

This multifunctional wheel-type scanner is an advanced tool designed for high-standard inspection environments. It combines fast phased array technology with a modular design to meet the demands of complex and highly stringent inspection tasks. Its unique tire material and standard modular design make it an ideal choice for conducting high-quality inspections in challenging environments.

Product Introduction

Professional Application Range

This scanner is specially designed to provide solutions for detecting defects such as delamination and debonding in carbon fiber reinforced composite materials in the aerospace industry. It is also suitable for aircraft skin inspection.

Wide Applicability

It is suitable for large-area corrosion or base material inspection of various types of sheet materials, as well as corrosion or base material inspection of large-diameter pipes made of different materials.

Advanced Technology Alternative

The scanner offers an easily implementable alternative to traditional 2D encoding systems. Additionally, the wheel-type scanner provides an effective replacement for liquid immersion testing technology, making it particularly suitable for environments where traditional liquid immersion techniques cannot be used.

Modular Design

Featuring a standard modular design, users can swap probes of different frequencies based on specific inspection needs, enhancing the versatility and flexibility of the equipment.



Electric Scanner

DSC03 Automatic Crawler Scanner

The DSC03 is a multifunctional electric scanner designed to carry welding inspection brackets and corrosion cross-axis scanning brackets, meeting diverse inspection needs. The main features of this scanner include exceptional stability and a high load-bearing capacity.

* next

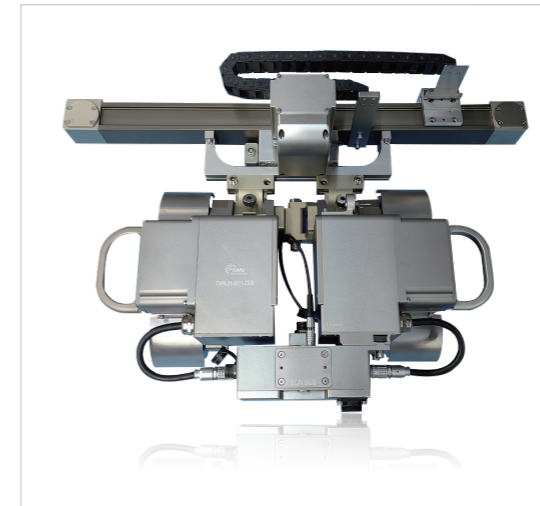

Features and Specifications

Adhesion Method: Permanent magnets, which maintain magnetic adhesion even after power loss.
 Scanning Methods: Lateral, longitudinal, grid scanning, and sawtooth scanning.
 Compatible Probes: Conventional ultrasonic probes, phased array probes, TOFD probes.
 Probe Capacity: Can carry 1-4 probes depending on customer requirements.

Applicable Range

For circumferential scanning on the inner wall of round pipes, the pipe inner diameter should be $\geq 2500\text{mm}$.
 For circumferential scanning on the outer wall of round pipes, the pipe outer diameter should be $\geq 300\text{mm}$.
 For axial scanning on the outer wall of round pipes, the pipe outer diameter should be $\geq 500\text{mm}$.

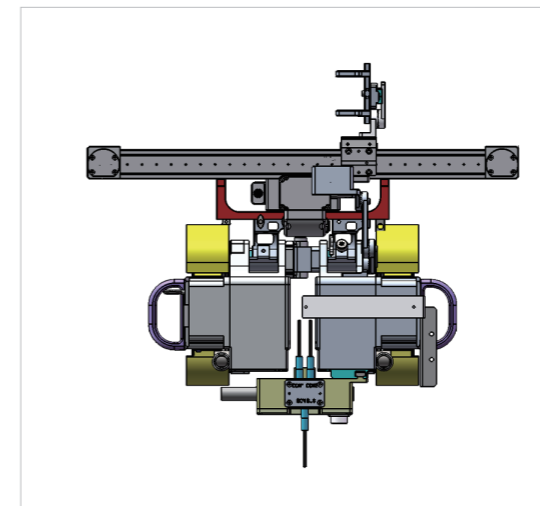

DSC03+ Corrosion Detection Specifications effective stroke of scanning arm: 300mm

Motion Methods: Vertical, horizontal, inverted, etc.
 Operation Mode: Automatic scanning, manual scanning
 Crawler Speed Range: 5mm/s ~ 120mm/s
 Electric Scanning Axis Speed Range: 10mm/s ~ 100mm/s
 Working Voltage: AC220V or DC24V
 Operating Temperature: $-10\text{C} \sim 50\text{C}$
 Waterproof Rating: IP66, suitable for harsh industrial inspection environments
 Video Function: Equipped with a Wi-Fi camera
 Coupling Agent Delivery System: Electric water pump for water supply, with a lifting height of no more than 20m

The illustrated probe holding arm can hold a 128-element phased array probe.

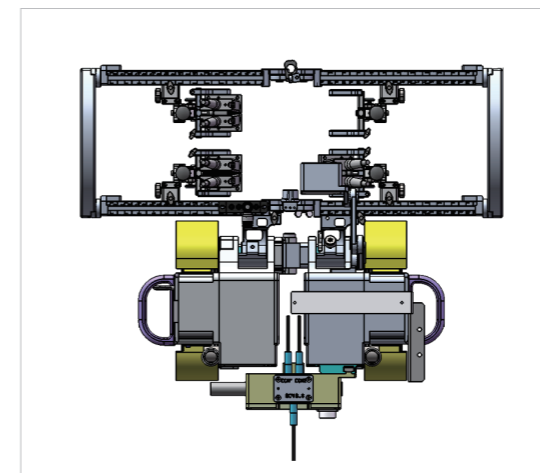

DSC03+ Weld Inspection

Equipped with the FC05 weld scanning device, it can effectively detect both longitudinal and circumferential welds. For inspecting circumferential welds on the outer wall, the minimum applicable pipe outer diameter is 300mm; for inspecting circumferential welds on the inner wall, the minimum applicable pipe diameter is 2500mm; for inspecting longitudinal welds on the outer wall, the minimum applicable pipe outer diameter is 500mm. When performing circumferential weld inspections, the device can be configured with up to four probes, while for longitudinal weld inspections, it can accommodate up to six probes. However, it is important to note that the maximum probe width should not exceed 50mm to ensure efficient and accurate inspection.

The illustrated holding frame can hold a 32-element or 64-element phased array probe.

Weld Inspection

Small and Simple / Single Probe

MOS01 Mouse-Type Scanner

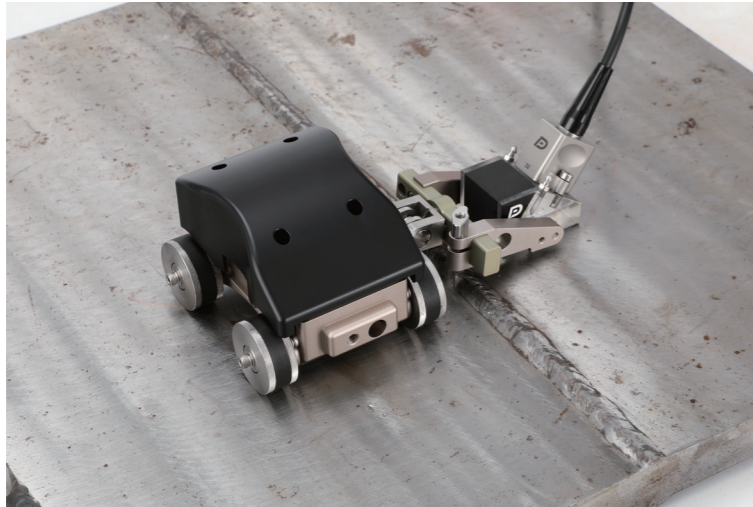

This scanner is suitable for circumferential scanning of pipes with a diameter of 100mm or larger.

The MOS01 is a versatile scanner designed specifically for industrial inspections. It integrates portability and high performance, providing great convenience for users. Equipped with advanced encoder technology, the scanner ensures accurate data acquisition. Additionally, its holding frame allows for easy swapping of different types of probes to meet the needs of various inspection tasks.

Application Scenarios

Petroleum and natural gas pipeline inspection
Corrosion inspection of pressure vessels and pipelines
Weld inspection of shipbuilding and offshore structures

MOS01

Optional accessories are available for inclined parallel scanning.

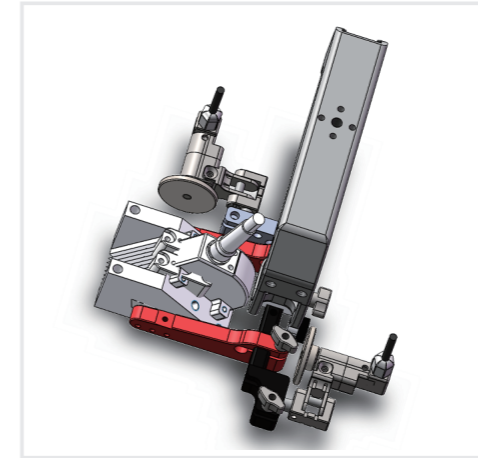

A32 Probe Fixation

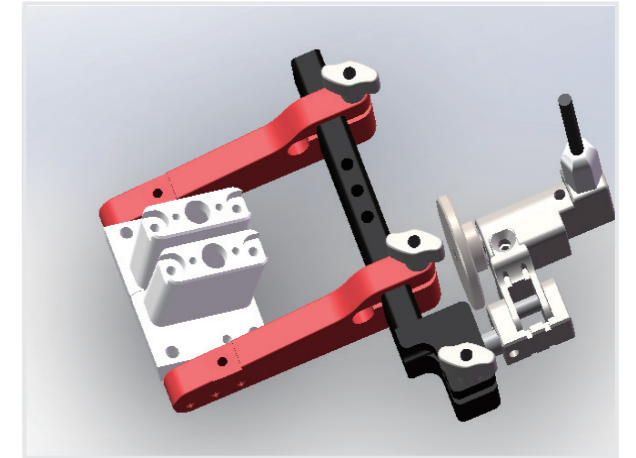

Without Handle State

Small and Simple / Dual Probe

MOS03 Dual Probes Scanner



- ✓ The MOS03 maintains the same core design as the previous MOS01, ensuring the continuation of the familiar portability and ease of operation for users.
- ✓ It can hold a pair of probes to perform a single set of TOFD or two sets of PA inspections, catering to different inspection needs.
- ✓ The newly added auxiliary wheels optimize the coupling effect between the probe and the workpiece, enhancing the stability and reliability of the inspection data.
- ✓ It supports probe combinations with a maximum width of up to 48mm, offering users a wider range of probe options and greater operational flexibility.
- ✓ The scanner supports efficient circumferential scanning for pipes with a diameter greater than 108mm, making the device highly suitable for inspections of pipelines and containers of various sizes.
- ✓ The integrated laser function provides a clear visual reference during circumferential scanning, ensuring high accuracy and efficiency throughout the inspection process.

CCE-2 Simple Scanner

The CCE-2 consists of an encoder, holding frame, and handle. Compared to the previous generation, the encoder's cable direction has been changed to face upwards, which increases the encoder's lifespan. The holding frame has a maximum width of 50mm and can hold wedges with a width range of 22mm-50mm.

Additionally, the CCE-2 features a handle designed for ergonomic comfort, improving user comfort during use. The handle also includes mounting holes to secure the cable to the handle, reducing the impact of the cable on probe coupling. The encoder has also been upgraded with an axial fixation method. In spaces with limited room, the handle can be detached for easier use.

Manual Multi-Probe Scanner / Pipe and Plate Welds / Magnetic Multi-Probe Scanner

FC14 Weld Inspection Scanner

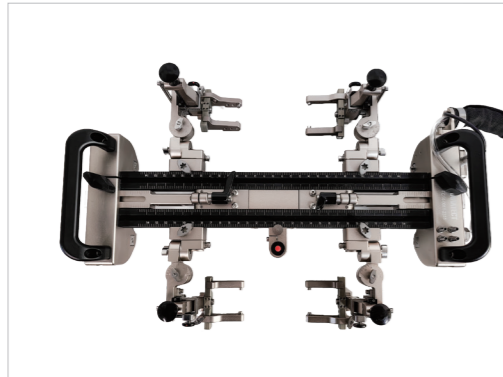

The FC14 scanner is an efficient tool specially designed for inspecting pipe or plate butt welds. This device can hold up to four probes simultaneously, supporting the inspection of both axial and circumferential butt welds.

FC14 Inclined Parallel Scanning Bracket (Optional)

FC14 inclined parallel scanning bracket codes: [2SP0446](#), [2SP0447](#)

☑ Component Composition

Magnetic Wheels: Ensure stable adhesion to the magnetic surface of the pipeline.

Water Supply Port: Provides coupling water to the probe.

Holding Frame: Fixes the probe in place, ensuring stability during the inspection process.

Scale Rod: Provides the operator with precise positional reference.

Support Frame: Ensures the correct positioning of the device on the pipeline.

☑ Main Features

Quick positioning and stable adhesion achieved through four magnetic wheels.

Laser indicator auxiliary function to enhance the accuracy of inspection data.

Suitable for inspection of various pipe diameters; axial mode adapts to diameters above 200mm, and circumferential mode adapts to diameters above 200mm.

Improves inspection efficiency and quality, making it suitable for weld inspection of various pipeline specifications.

FC30 Weld Inspection Scanner

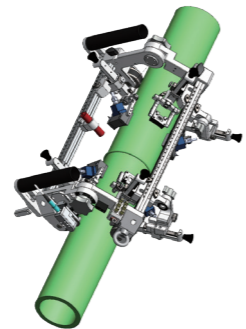
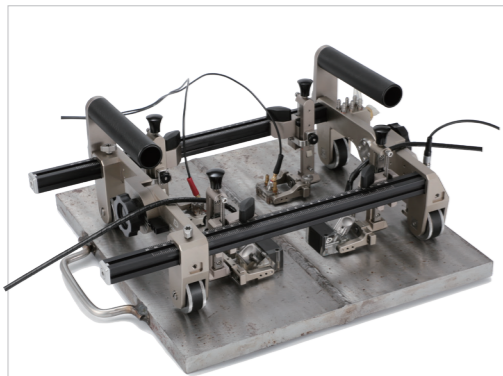

This scanner, with its standard configuration, allows for the installation of four probes and can be expanded to accommodate up to eight probes, providing flexible and adaptable inspection solutions based on detection needs.

☑ Core Features

Magnetic Adhesion Technology: Four magnetic wheels ensure secure attachment to the magnetic surface of the pipeline, specifically designed for circumferential weld detection.

Swing Joint Design: The swing joint at the central position allows users to easily adjust the probe holder, ensuring precise coupling with the pipeline surface.

Laser Indicator: Provides accurate guidance to the inspection area, offering reference markers that significantly improve both the accuracy and convenience of the inspection.

Wide Applicability: The scanner is suitable for pipes with a minimum diameter of 110mm, compatible with various pipe specifications, supporting a wide range of weld inspection tasks.

Pipeline Manual Chain-Type / Small Diameter Pipes

(ϕ 20-114mm) / Standard Model (Width \geq 256mm)

CRS7/CRS8 Chain Scanner (Small Pipes)

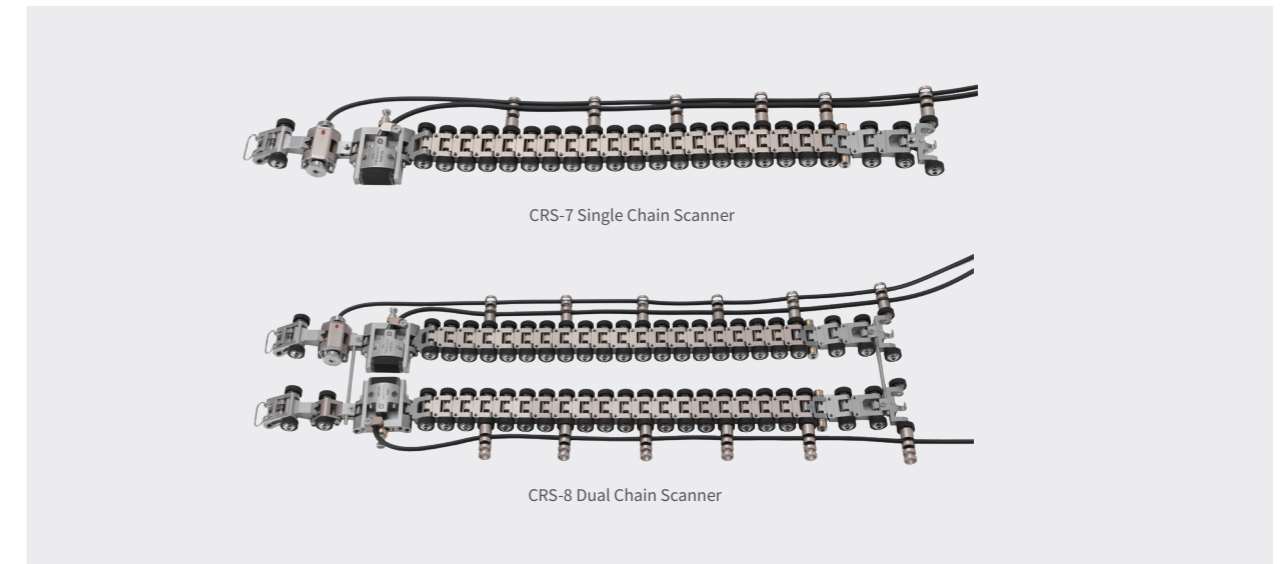

☑ CRS7/8 Product Features

The slim and flat chain structure is specifically designed for extremely small inspection spaces, allowing it to pass through pipe gaps as small as 13mm.

Highly modular design, including the scanner main frame, encoder, quick-release chain module, and locking block. The effective combination of these components ensures flexibility and reliability when inspecting pipes of different diameters.

By adding or removing chain components, the device can be quickly adjusted to fit different pipe sizes without the need for complex tools, significantly improving work efficiency.

The quick-release chain design simplifies the assembly process, reduces the need for specialized tools, and enhances both ease of use and accuracy during operation.



Pipeline Manual Chain-Type / Medium Diameter Pipes (φ50-300mm)

CRS-25 Chain Scanner (Small Medium Diameter Pipes)

The CRS-25 is an efficient inspection tool specifically designed for detecting circumferential welds on medium and small diameter pipes ranging from 50 to 300mm. This scanner is lightweight and durable, equipped with a quick-release chain, greatly enhancing convenience for users in terms of both usage and portability.

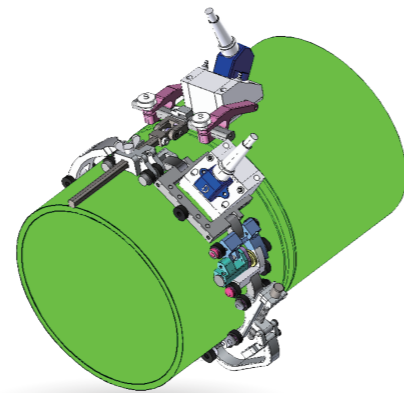
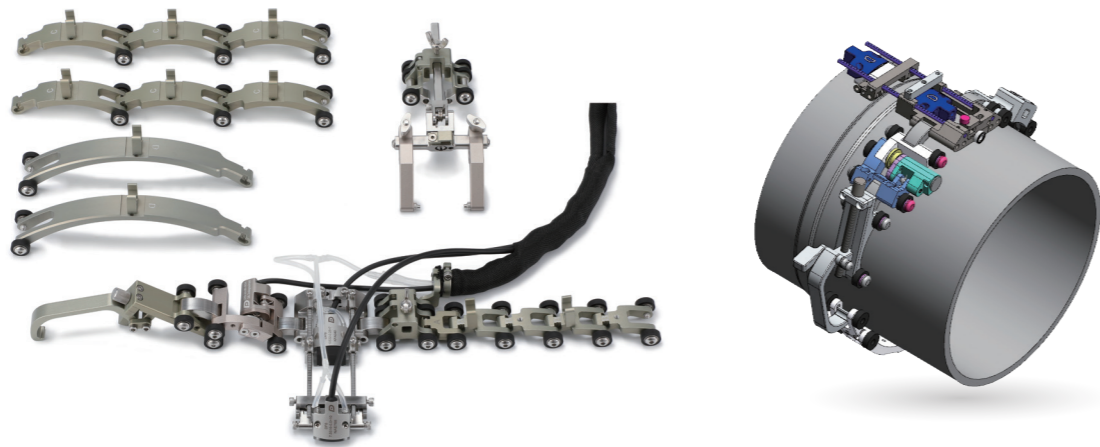

The CRS25 is equipped with the DP2 probe holding frame (standard configuration).

DP2 Probe Holding Frame Code: 2SP0544

Pipeline Manual Chain-Type / Large Diameter Pipes(φ150-1220mm)

MOS04 Chain Scanner (Large Pipes)

The MOS04 multi-probe long-distance pipeline weld scanner is developed to meet the demands of high-efficiency, large-area weld inspection. It combines specialized detection modes, a highly compatible probe holder, multi-probe configurations, excellent waterproof performance, and a quick-release chain design, offering outstanding performance and significant convenience for long-distance pipeline inspection tasks.

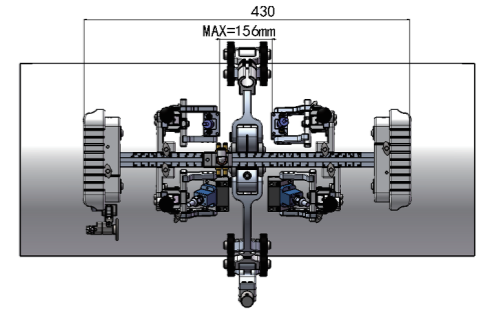

Wide Pipe Diameter Compatibility: The scanner is suitable for both magnetic and non-magnetic materials and adapts to a wide range of pipe diameters, from Φ6" (Φ150mm) to Φ48" (Φ1220mm). Other specifications can be customized upon request to ensure versatility in various pipeline inspections.

Multi-Mode Support:

Supports both PA and TOFD detection simultaneously, providing flexible options for different inspection scenarios.

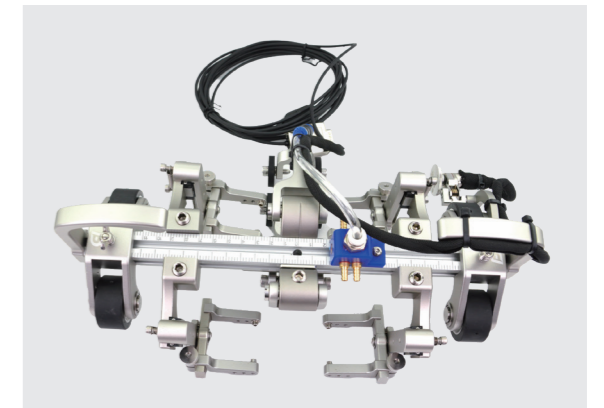
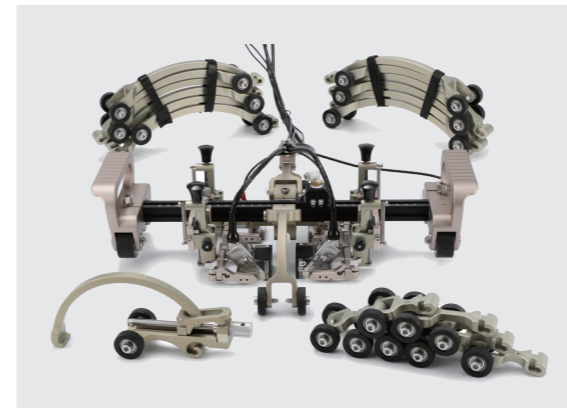

High Compatibility Probe Holder:

The probe holder is compatible with wedges or probes with a maximum width of 46mm, ensuring adaptability with a variety of inspection equipment.

Multi-Probe Configuration:

It can hold up to four probes simultaneously, significantly improving inspection efficiency and data acquisition speed, making it especially suitable for high-efficiency inspection tasks.

IP67 Encoder Waterproof Rating:

The high standard waterproof performance ensures reliable operation of the device in humid and underwater environments.

Quick-Release Chain Design:

The quick-release chain design allows for easy replacement of the chain, enabling operators to quickly switch between different pipe diameters, improving convenience and efficiency during on-site operations.

Various Electric / Pipeline Circumferential Welds / Rail-Type

DSC27 Guide Rail Scanner

This scanning device is equipped with compatible pipeline rails for use. The main body of the scanner is a remote-controlled crawler, suitable for both metallic and non-metallic round pipes. The steel band rail is fixed onto the circular workpiece, and the crawler is mounted onto the rail. It can carry multiple pairs of probes to inspect the welds of the workpiece. (Note: Different pipe diameters require different rails.)

Performance Features

Applicable to pipes with an outer diameter \geq 400mm

Crawler speed range: 0.2~2.36in/sec (5~60mm/sec)

Waterproof rating: IP65

Operating temperature: -4°F~122°F(-20°C~50°C)

Power supply voltage range:

When using AC mains power, 110V AC or 220V AC. Users should provide the local mains voltage before ordering to ensure proper factory setting of the appropriate operating range.

When using batteries, the voltage range is 20~30V, with a maximum current of at least 10A. The crawler's power module will automatically adjust to the supplied voltage.

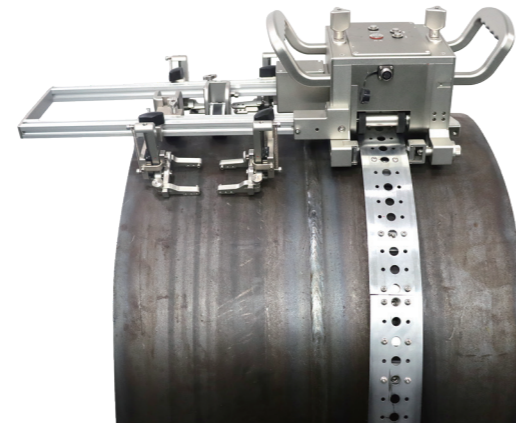

Dual Encoder Configuration: The standard model is equipped with two encoders. One is installed on the chain to record the position information of the branch pipe, while the other is mounted on the probe's stepping axis. This setup ensures the accuracy and reliability of the inspection results.

IP67 Protection Rating: The encoders are designed with high waterproof performance, allowing the equipment to operate stably even in humid and underwater environments. This enhances the equipment's environmental adaptability and durability.

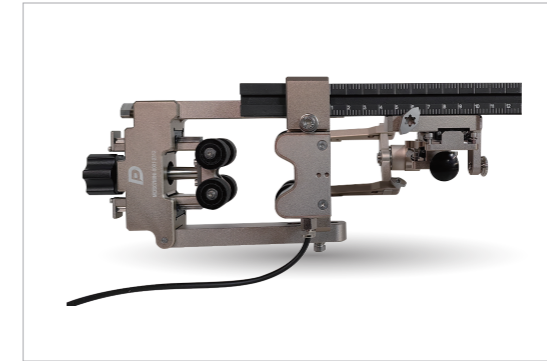

Custom Model for Small Pipe Diameters: Supports inspection of branch pipe diameters from Φ 20mm to Φ 50mm and main pipe diameters above Φ 500mm.

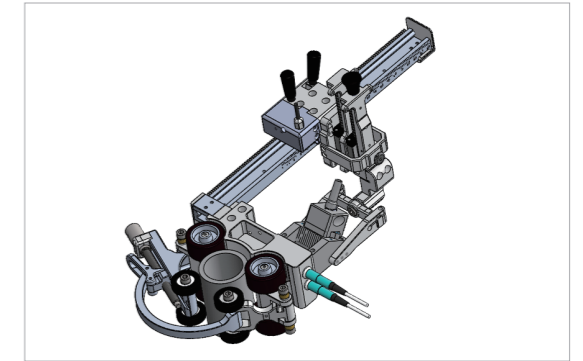

Standard Model: Supports inspection of branch pipe diameters above Φ 50mm and main pipe diameters above Φ 500mm. This model covers most industrial pipe sizes, offering more possibilities for pipe inspection across various scales.

Nozzle Weld Scanner

MOS07 Nozzle Weld Scanner

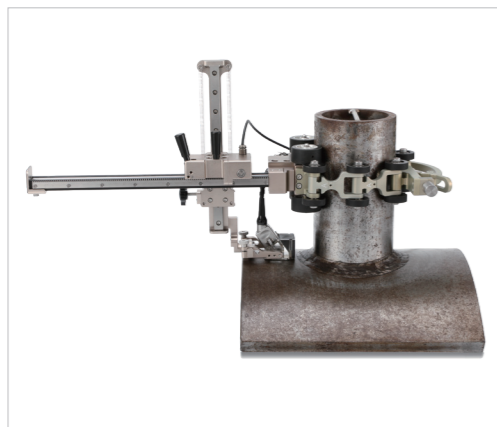

The MOS07 is specially designed for the detection of complex pipe seat welds, providing precise inspection data.

Its flexible probe holding system can securely support a probe with a maximum clamping width of 48mm, compatible with various probes.

Custom weld angles: The probe angle can be adjusted based on the weld angle to ensure optimal coupling.

Quick chain replacement: Featuring a quick-release chain design, operators can quickly and easily switch between different pipe diameters, greatly improving on-site operational efficiency.

DSC52 Tube-Sheet Scanner



This weld scanning device is primarily used for detecting the angle welds of boiler heat exchanger tube plates and is suitable for inspecting internal welds with an internal diameter of 15mm and above. The rotating mechanism, powered by an efficient drive system, enables the probe to rotate fully around the pipe center, ensuring precise weld inspection. The drive unit integrates a commutator, gearbox, and encoder, providing strong power while effectively preventing probe cable entanglement, thereby improving both inspection efficiency and safety.

03

SCANNER
PRODUCT

Encoder

ENC-10 Wheel Encoder



This compact encoder is specifically designed for modern industrial inspection needs, offering miniaturization, high adaptability, and strong durability. It is compatible with various probes, providing great flexibility to meet different inspection requirements. Its compact size makes it suitable for space-constrained or structurally complex working conditions. With an IP67 dustproof and waterproof rating, it ensures reliable operation in harsh environments. When used with specialized accessories, it allows for 90° angle adjustments, offering multiple detection angle options. The steel wheel rolling design ensures smooth operation and slip resistance, while also supporting wheel replacement to adapt to special surfaces. It is widely used in industries such as aerospace, automotive manufacturing, and petrochemical, making it an ideal choice for improving inspection efficiency and accuracy.

LX14 Rope Encoder

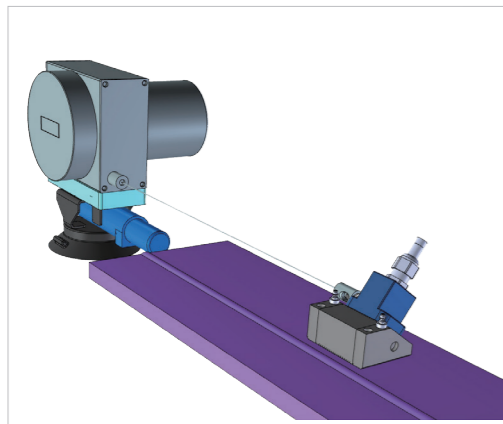

This multifunctional compact inspection accessory is designed to enhance industrial inspection efficiency and accuracy, and is widely used in industries such as aerospace, automotive manufacturing, and petrochemicals. It features an aluminum alloy housing, making it lightweight, durable, and easy to carry on-site. The compact design is ideal for environments with limited space. The U-shaped slot at the end of the pull cord supports quick connection to various probes or scanners, increasing flexibility. The side magnets and bottom vacuum suction cup provide dual stability, preventing slipping. With an encoder stroke of up to 1000mm, it offers ample adjustment space to meet different inspection needs, making it an ideal tool for on-site inspection engineers.

PE Pipe Butt Joint Inspection

MOS05-D PE Pipe Heat Fusion Scanner

MOS05-D special scanner for hot-melt butt joint inspection is an efficient tool designed for PE pipeline maintenance and quality assurance.

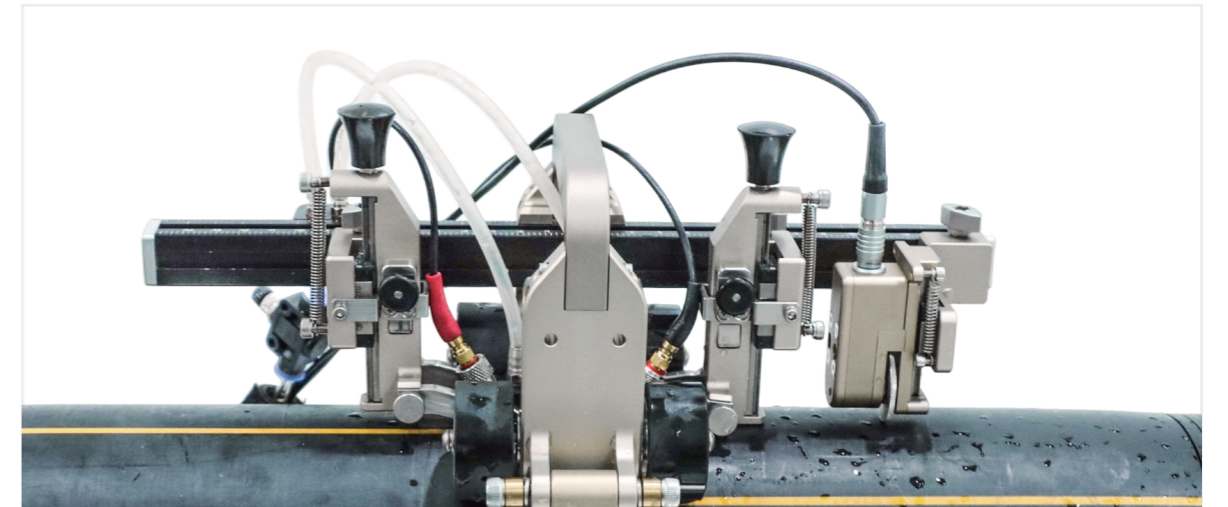

Efficient quick-release chain

The convenient quick-release chain design enables operators to quickly adjust the chain length to adapt to different working environments and improve working efficiency.

Adequate radial clearance

A radial clearance of at least 120mm is needed to place and operate the scanner, which ensures sufficient space for operation in the detection process and improves the flexibility and convenience of use.

Wide pipe diameter applicability

It is suitable for PE pipes with diameters ranging from $\phi 60\text{mm}$ to $\phi 400\text{mm}$, covering most common pipe diameters, which provides great convenience for pipeline inspection of various scales.

TOFD probe compatibility

Specially designed to clamp the TOFD probe matched with the hot melt defect detection of PE pipe to ensure the professionalism and accuracy of the detection process.

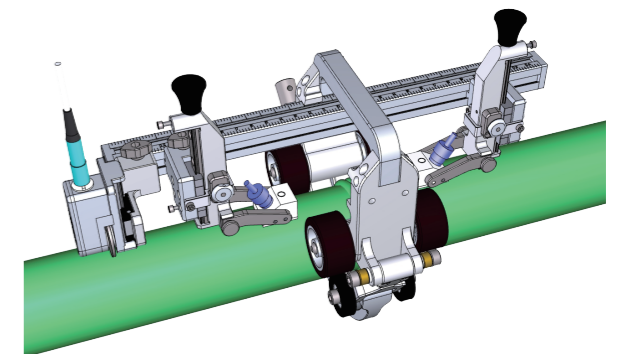

MOS05-B PE Pipe Electrofusion Scanner

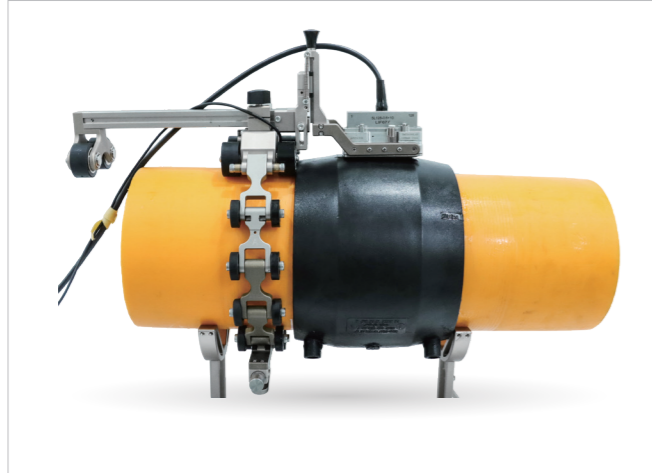

MOS05-B is specially designed for the detection of electric welding joint of PE pipeline, which is suitable for the detection of coaxial reducing pipeline, and the probe and wedge can be flexibly matched. IP67 protection level ensures stable operation in wet environment and improves durability. Suitable for pipe diameter detection from $\Phi 90\text{mm}$ to $\Phi 400\text{mm}$, other specifications can be customized.

PE01 PE Pipe Electrofusion Joint Scanner

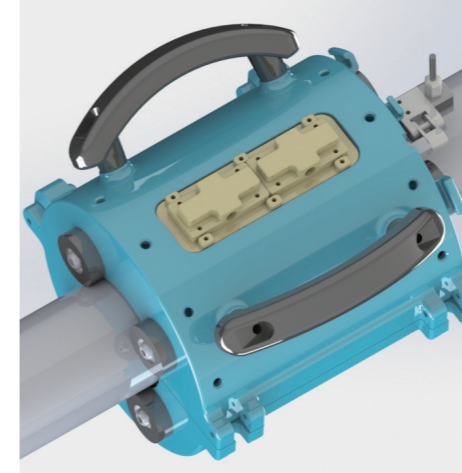

Components

Water Bag: Custom-made according to the workpiece size, paired with a specialized sealing ring to ensure the water chamber is airtight, achieving excellent acoustic coupling.

Probe: Multiple models are available to meet the requirements of different inspection processes.

Support Wheels: Ensure the water bag remains stable and assist its smooth movement across the workpiece surface, enabling comprehensive inspection.

Customization Service Range: This scanner can be customized to support pipe diameters ranging from 32mm to 90mm, meeting various application needs.



Product Advantages

Ensures excellent coupling performance between the probe and the workpiece, improving inspection accuracy.

Designed to avoid obstacles on the workpiece, ensuring an uninterrupted inspection process.

Highly adaptable, offering customized solutions for various pipe sizes.

The encoder provides precise positioning, simplifying subsequent data analysis.



04

CONVENTIONAL UT PROBE [∨]

- Contact Probe
- Immersion Probe
- Hyperbolic Ultrasonic Transducer
- Air-coupling Probes
- Probes for Custom and Specific Applications
- Cables
- Adapters

* The probe specification table in this chapter only displays the scope of capabilities. For specific models and parameters, please refer to the Probe Selection Manual, which can be downloaded from the official website or obtained by consulting the sales manager.

Up to now, Doppler has designed and developed a series of standard probes, customized probes and related accessories, with more than 4,000 specifications and models, which are widely used in aerospace, nuclear power, petrochemical, machinery manufacturing, shipping, railway transportation, medical and other industries; Doppler continuously introduces outstanding talents every year, invests in important R&D, testing and production equipment, and has many years of experience in transducer design, which provides an important guarantee for continuously improving product performance, improving production efficiency and optimizing manufacturing technology. These persistent efforts are enough to ensure that the quality of our products has always been at the forefront of the industry, and Doppler ultrasonic probes can be seen in many major national key research projects and special testing problems in various industries.

Most standardized transducer products are summarized in this manual, and almost all the Models you need can be found in the manual. For customized products or unsolvable detection problems, our application center and probe design experts are very happy to help you find a suitable solution.

04

CONVENTIONAL PROBE



Instruction of Conventional UT Probes

- ✓ Ultrasonic Probe is the most essential part of ultrasonic detection systems, to choose the right probe can ensure a smooth detection work and accuracy of test results
- ✓ Doppler provides three different kinds of performance probes, with unique application and performance characteristics
- ✓ Below shows transmitter, configuration, cable, crystal Frequency, crystal size etc., characteristics and applications of three types of probes

PL-Universal Series

Applications

- ✓ General inspection environments

Features

- ✓ With appropriate sensitivity and resolution
- ✓ Longer duration of wave, typically at 3~5 cycles
- ✓ Lower bandwidth, typically at 30~50%

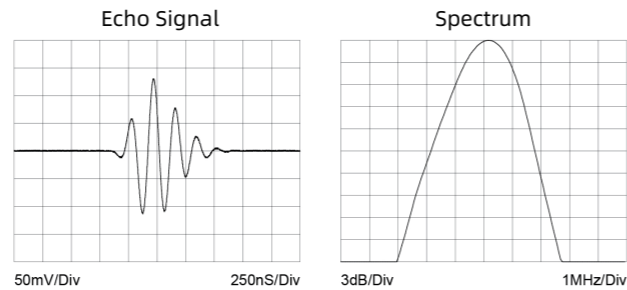

PH-Short Pulsing Series

Applications

- ✓ Ideal for precise thickness measurement, near surface detection environments

Features

- ✓ Excellent vertical and horizontal resolutions
- ✓ Tiny blind spot width of initial pulse
- ✓ Less Sensitivity than PL and C Series
- ✓ Shorter duration of wave, typically at 1.5~2 cycles
- ✓ Higher Bandwidth, typically at 80~110%

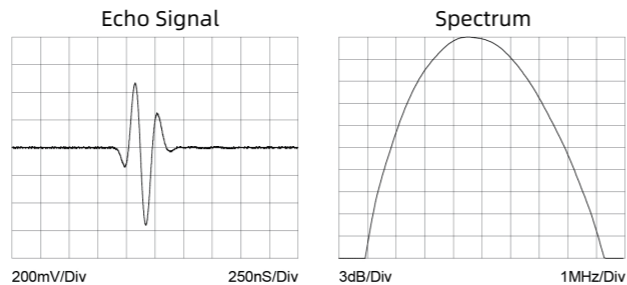

C-Composite Series

Applications

- ✓ High penetration power and high SNR for coarse-grained, fiber-reinforced composite materials

Features

- ✓ Composite ceramic crystal
- ✓ Sensitivity is usually higher than PL and PH series.
- ✓ The echo duration is short, and most oscillation periods are usually 2~2.5.
- ✓ Higher bandwidth, most of which is usually 70~100%.
- ✓ The composite ceramic crystal with low acoustic impedance can better match the probe with low acoustic impedance media such as water and plastic.

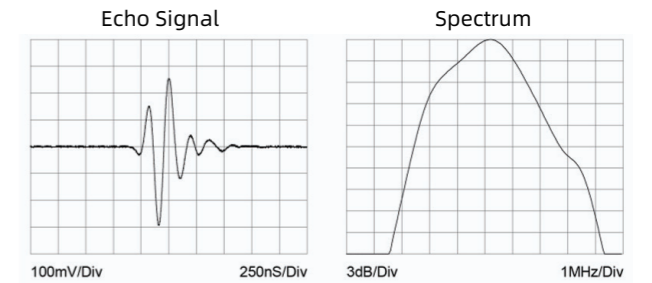

Probe Data Sheet

Each transducer sold by Doppler has undergone strict testing and certification with reliable detection equipment and stable testing environment. The data sheet can truly and effectively reflect the performance of the transducer, which contains basic parameters that need to be paid attention to in daily use, as well as a large number of characteristic parameters. It helps users to make comparing and researching of the probes characteristics.

Data Type	Description
CN	Complied to Chinese GB/T 27664.2 testing standards
EN	Complied to European EN ISO 22232-2 testing standards
AT	Complied to North America ASTM E-1065 testing standards
CS	Any probe other than "CN", "EN" and "AT", providing echo and spectrum diagram, center frequency, pulse width, bandwidth, sensitivity and other important data
LFA	For twin crystal longitudinal wave angle probes, analysis relationship between angles, focal depth and focal points, center frequency, bandwidth, sensitivity and relevant important data
DGS	Provide probe DGS curve (to be ordered separately) to describe the relationship between distance, gain and equivalent size for regular reflector

04

CONVENTIONAL PROBE

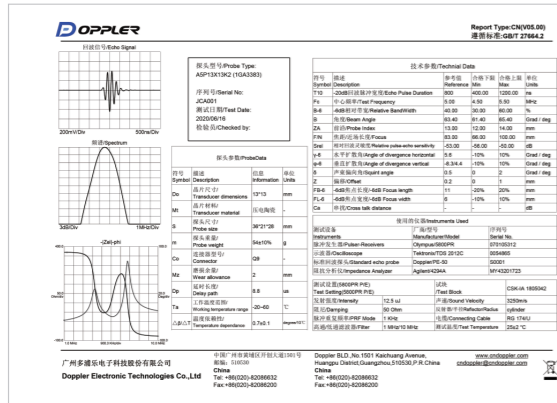

CN

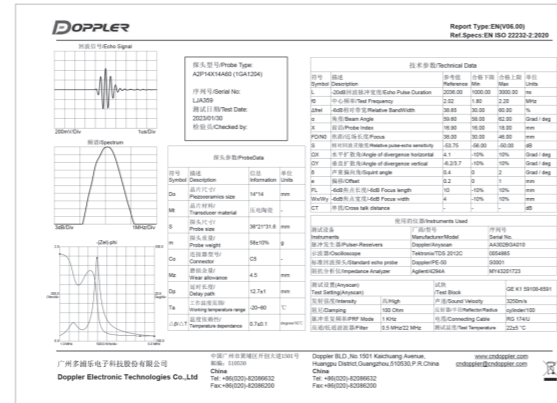

EN

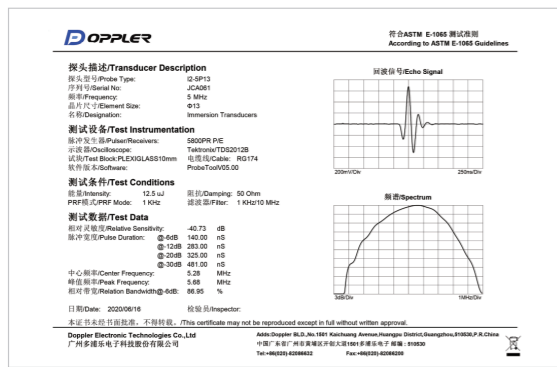

AT

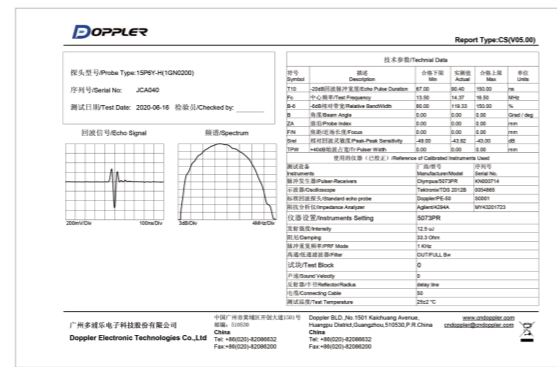

CS

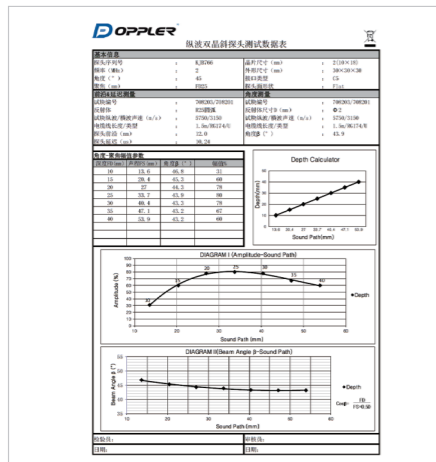

LFA

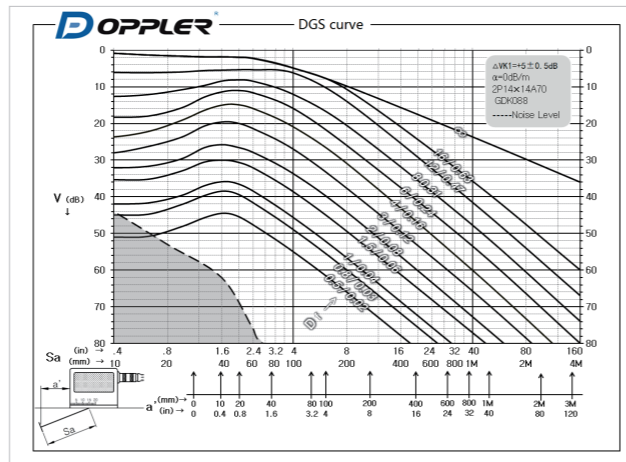

DGS

Contact probe

Normal Beam Probes



A single crystal transducer, sound wave vertical incidence and direct contact.

Features

- ✓ Wear resistant stainless steel housing
- ✓ Wear resistant front end protective layer, long service life
- ✓ Good match acoustic impedance with most metals
- ✓ 3 types of performance to meet the cast majority of testing requirements: "PL" Universal Series, "PH" Short Pulsing Series, "C" Composite Series



Applications

- ✓ Simple structure of metals
- ✓ Large plates, bars, forgings, metals and non-metals
- ✓ Small tanks, pipes, castings, bars
- ✓ Sandwich and laminated structures
- ✓ Materials velocity and characteristics
- ✓ Coarse grain or high attenuation materials

04

CONVENTIONAL PROBE

China Standard - N1

- By default, the probe interface is side mounted BNC and Q6, and the top mounting direction of the interface can be customized.



Model	Frequency (MHz)	Size (Φ/mm)	Type	Interface	Standard
N1	1/2.5/5	10/14/20	PL/PH	BNC/Q6	GB/T27664.2

European Standard - N2

- Microdot(L5), Lemo 00(C5), and Lemo 01(C9) side mounting connectors, for above φ5 can be customized as top mounting connector.



Model	Frequency (MHz)	Size (Φ/mm)	Type	Interface	Standard
N2	1/2/4/5/10	5/10/24	PL/PH	L5/C5/C9	EN ISO 22232-2

European Standard - N3

- Low height probes, suitable for narrow and limited detection environments
- Lemo 00 (C5) side mounting connector, with handle bar



Model	Frequency (MHz)	Size (Φ/mm)	Type	Interface	Standard
N3	1/2/4/5/10	10/20	PL/PH	C5	EN ISO 22232-2

North American Standard - N4

- Large crystal diameter to ensure high sensitivity of probe, and wider coverage area of detection
- BNC(Q9) side mounting connector, can be customized as top mounting connector



Model	Frequency (MHz)	Size (Φ/mm)	Type	Interface	Standard
N4	0.5/1/2.25/3.5/5/7.5/10	13/19/25/29	PL/PH/C	BNC	ASTM E-1065

North American Standard - N5

- Low height probes, suitable for narrow and limited detection environments
- L5(Microdot) side mounting connector, with handle bar can be customized as top mounting connector



Model	Frequency (MHz)	Size (Φ/mm)	Type	Interface	Standard
N5	1/2.25/3.5/5/7.5/10/15/20/25	3/6/10/13/19/25	PL/PH/C	L5	ASTM E-1065

Normal Shear Wave Probes



The normal shear wave probe is a single-element transducer that directly contacts the workpiece and generates transverse wave by vertical incidence.

Features

- Incident vertically and generate shear waves inside the workpiece
- Sensitivity is usually lower than that of LW straight probe
- Low probe height, suitable for the situation of limited space
- High viscosity couplant is required, and the order code of couplant is 6J50124*
- The polarization direction of shear wave is consistent with the interface direction
- Probe interface is side mounted Microdot by default, top mounting can be customized

Applications

- Measurement of shear wave sound velocity of workpiece
- Calculation of Young's modulus of elasticity and shear modulus
- Analysis of workpiece grain structure

Model	Frequency (MHz)	Size (Φ/mm)	Type	Interface	Standard
SN	0.5/1/2.25/2.5/4/5	6/10/13/19/25	PH	L5	ASTM E-1065



*In order to obtain the best coupling effect between probe and workpiece, we suggest placing a small amount of high viscosity coupling agent on the surface of the probe and scraping the coupling agent into thin sheets with a blade or card; Couple the probe to the workpiece and rotate it while pressing down.

04

CONVENTIONAL PROBE

Soft Protective Membrane Probes



Replaceable protective films, sound wave vertical incidence and direct contact with workpiece.

Features

- Provide soft film or wear-resistant cover for different applications
- The soft film can reduce the effect of coupling on uneven or rough surfaces
- The wear-resistant cover is suitable for rapid scanning on rough surfaces
- The front soft film and wear-resistant cover can be replaced to prolong the service life of the probe
- For European standard only provides the soft film option, for the North America standard we can provide both the soft film and wear-resistant cover

Applications

- Simple structure of metals
- Large plates, bars, forgings, metals and non-metals
- Small tanks, pipes, castings, bars
- Sandwich and laminated structures



European Standard PF1

Model	Frequency (MHz)	Size (Φ/mm)	Type	Interface	Standard
PF1	2/4/5	10/24	PL	C5/C9	EN ISO 22232-2

North America Standard PF2

Model	Frequency (MHz)	Size (Φ/mm)	Type	Interface	Standard
PF2	1/2.25/3.5/5	13/19/25	PL	BNC	ASTM E-1065



Dual Element (TR) Probes



Independent transmit and receive crystals, and creates a certain focal length in workpiece.

Features

- No initial pulse dead zone effects
- Less scattering, higher SNR in high attenuation material
- Good coupling on curved and rough surfaces
- Two types of performance probes can meet most of detection needs "PL" Universal Series, "C" Composite Series

Applications

- Corrosion monitoring
- Residual wall measurement
- Coating measurement
- Near surface defects detection
- Cracks, porosities, impurity and porosity detection of forgings
- High attenuation material detection

China Standard

- PL Series is the default probe type.
- Top-mounted Microdot and Q6 connector

Model	Frequency (MHz)	Size (Φ/mm)	Type	Interface	Standard
DA	2.5/5	10/14/20	PL/C	L5/Q6	GB/T27664.2



European Standard

- PL Series is the default probe type.
- Lemo 00(C5) and Microdot (L5) side mounting connector

Model	Frequency (MHz)	Size (Φ/mm)	Type	Interface	Standard
DA	1/2/4/5/10	5/8/9/11	PL	L5/C5	EN ISO 22232-2
		3.5×10			
		7×18			
		6×20			



North America Standard

- Low height probes, suitable for narrow and limited detection environments
- Side mounting with 1.8 meter cable length, cable end with Lemo 01(C9), or BNC(Q9) connectors (optional)

Model	Frequency (MHz)	Size (Φ/mm)	Type	Interface	Standard
DA3	2.25/3.5/5/7.5/10	6/10/13	PL/C	BNC/C9 (zone line)	ASTM E-1065



04

CONVENTIONAL PROBE

Angle Beam Probes



Refracting ultrasonic beams and generate shear or longitudinal waves to workpiece through a fix angle of delay line.

Features

- ✓ Ergonomic design, with durable cast housing
- ✓ Customizable any theoretical angles of ultrasound
- ✓ Probe face can be processed into different shapes to ensure good coupling with workpiece:
 - AID(Axial Inside Diameter) CID(Circumferential Inside Diameter)
 - AOD(Axial Outside Diameter) COD(Circumferential Outside Diameter)
- ✓ Three types of performance can meet the most of detection needs:
 - "PL " Universal Series, "PH " Short Pulsing Series, "C " Composite Series

Applications

- ✓ For welding inspection
- ✓ Pipes, pressure vessels, storage tanks
- ✓ Turbine blades
- ✓ Wheel axles, castings, forgings
- ✓ Bond testing
- ✓ Railway wheels and tracks



China Standard

- ✓ The default "performance type" of probe is PL series.
- ✓ By default, the probe is installed obliquely or sideways with BNC and Microdot interfaces, and the 6×6 specification can customize the top mounting direction of the interface.

Model	Frequency (MHz)	Size (Φ/mm)	Type	Interface	Standard
A1	2.5/5	6×6	PL/C	L5/Q9	GB/T27664.2
		9×9			
		8×12			
		10×16			
		13×13			



European Standard

- ✓ PL Series is the default probe type
- ✓ Microdot(L5), Lemo 00(C5), and Lemo 01 (C9) top side mounting connectors, all models can be customized for top mounting except size 3*4mm

Model	Frequency (MHz)	Size (Φ/mm)	Type	Interface	Standard
A2	1/2/4/5/6	3×4	PL/C	L5/C5/C9	EN ISO 22232-2
		5×5			
		8×9			
		14×14			
		20×22			



North America Standard A3

- ✓ The probe and delay line can be disassembled quickly
- ✓ Delay lines are divided into two types: standard cutting edge and short cutting edge
- ✓ The corresponding thread is 1/2-28 and 5/8-24 for probes and delay line with diameter 10mm and 13mm separately. OP type can be indicated when ordering with corresponding thread 9/16-24 and 11/16-24
- ✓ Microdot top mounting connector

Model	Frequency (MHz)	Size (Φ/mm)	Type	Interface	Standard
A3	1/2.25/3.5/5/7.5	6/10/13	PL/PH/C	L5	ASTM E-1065



North America Standard A4

- ✓ The larger wafer size enables the detection of thicker workpieces
- ✓ Delay lines are divided into SL and RL, among which RL series conforms to the requirements of 《AWS Specification》 D1.1
- ✓ High temperature resistance series delay line can be customized
- ✓ The probe is equipped with a non - falling screw and delay line can be disassembled tool free
- ✓ The probe interface is BNC top by default

Model	Frequency (MHz)	Size (Φ/mm)	Type	Interface	Standard
A4	0.5/1/2.25/3.5/5	13/25	PL/PH/C	BNC	ASTM E-1065
		13×25			
		16×16			
		19×19			
		19×25			



04

CONVENTIONAL PROBE

TRL Angle Beam Probes

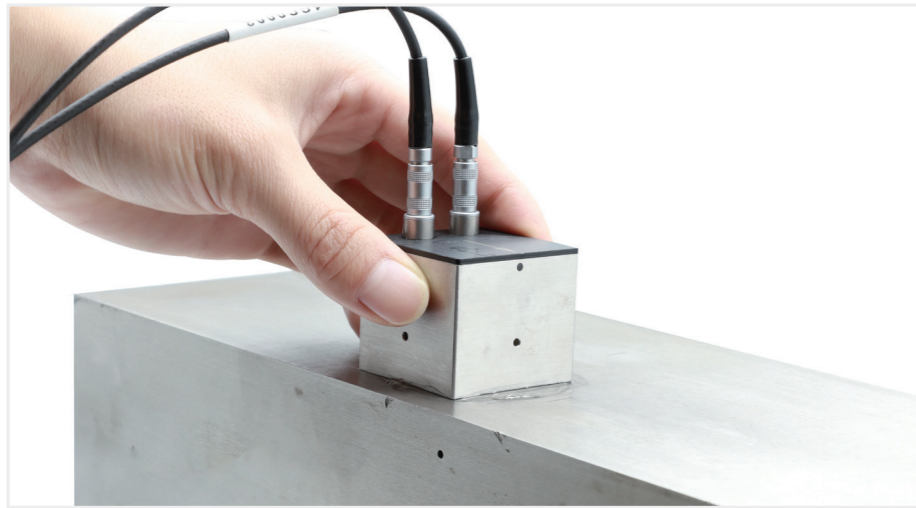

Independent transmit and receive crystals, refracting ultrasonic beam angles and creates certain focal length in workpiece.

Features

- No initial pulse dead zone effects
- Less scattering, higher SNR in high attenuation material
- All refractive angles are longitudinal waves and can be customized to any longitudinal wave angle within ultrasonic theory
- Probe face can be processed into different shapes to ensure good coupling with workpiece:
AID(Axial Inside Diameter), CID(Circumferential Inside Diameter), AOD(Axial Outside Diameter), COD(Circumferential Outside Diameter)
- Two types of performance probes can meet most of detection needs: "PL " Universal Series, " R " High Performance Series

Instructions

- R series is the default probe type
- Default delay lines is 4mm exposed, and the delay lines can be customized and embedded
- The default shell of the probe is DA type, with no inlet pipe or water guide groove. If the probe needs to be clamped and scanned with a fixture, it can be replaced with a CDA type shell (inlet pipe+water guide groove+clamping hole)
- FS means sound path, FD means focal depth, conversion of FS, FD and β is:
 $\cos\beta=FD/(FS+0.5D)$, where D is diameter
- The engraved lines on both sides of the shell indicate the incident point, the arrow at the top indicates the direction of the sound axis, and the red circle at the top indicates that the interface on this side is the transmitting end (T)
- The probe interface defaults to the top mounted Lemo-00 and can be customized with a side mounted direction

Applications

- Nuclear power station
- Austenitic stainless steel
- Near surface flaw detection
- Plate weld inspection
- High attenuation materials



Specifications

Model	Frequency (MHz)	Size (Φ/mm)	Type	Interface	Standard
DA	0.5/1/2/4	7×10	PL/R	C5	EN ISO 22232-2
		8×14			
		10×18			
		15×25			
		20×34			

Delay Line Probes



With replaceable delay line at the front of probe, and sound wave vertical incidence into workpiece.

Features

- Replaceable delay lines
- High bandwidth and narrow pulse with delay line, ensure excellent near surface resolution
- Higher frequency increases resolution of detection
- <Note>: Thickness of delay line decides the maximum thickness of workpiece, Doppler Provide 3 different thicknesses of delay lines to meet the most detection cases; Length and materials of delay line can be customized.

Applications

- Direct flaw detection
- Precise thickness measurements
- Near surface flaw detection
- Surface detection of curved workpiece
- Ultra thin workpiece detection

Delay Line (DL)

- Delay line can be purchased separately
- Microdot (L5) side mounting connector
- Default length of delay lines: Φ3mm(0.125in) crystal probe with 5.5mm(0.22in) length of delay line Φ5/6/13mm(0.2/0.25/0.5in) crystal probe with 12.7mm(0.5in) length of delay line

Model	Frequency (MHz)	Size (Φ/mm)	Type	Interface	Standard
DL	2.25/3.5/5/10/15/20	3/5/6/13	PH	L5	ASTM E-1065



Delay Line (P)

- Replaceable delay lines
- Ultra small contact area of probe front, suitable for high bending surface detection, such as turbine blades
- 3 types handle bars: horizontal, 45° and 90°
- Replaceable horizontal handle bar
- Delay line can be purchased separately, model: 1GW2912
- Microdot (L5) tail-end mounting connector

Model	Frequency (MHz)	Size (Φ/mm)	Type	Interface	Standard
P	10/15	3	PH	L5	ASTM E-1065



04

CONVENTIONAL
PROBE

Spot Weld Probes



The spot welding probe is a single element transducer that contacts the workpiece through a specific water column.

Features

- The soft film can reduce the impact of coupling on uneven spot welding
- Different element sizes are used to measure the quality of spot welding of different sizes
- The probe interface is side mounted Microdot by default

Applications

- Integrity measurement of spot welding quality in automobile or other industries



Specifications

Model	Frequency (MHz)	Size (Φ/mm)	Type	Interface	Standard
SWI	15/20	2.5/3/3.5/4/4.5/5/5.5/6	PH	L5	ASTM E-1065

TOFD Probes

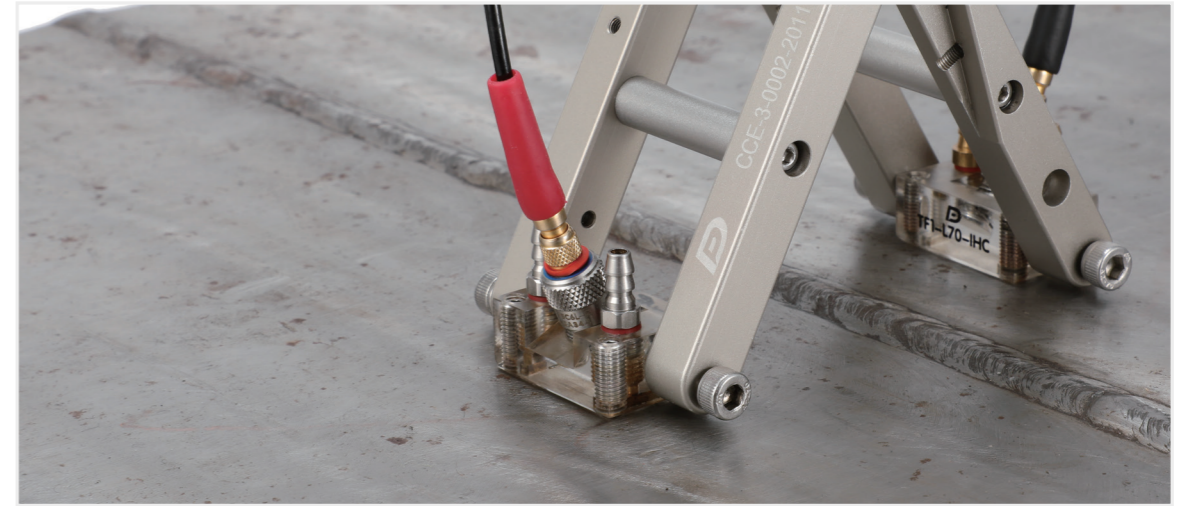

TOFD Probe and Delay Line can generate refracting longitudinal in steel, and use time of flight diffraction technique to determine the cracks.

Features

- High damping and wide bandwidth performance
- High efficiency for welding inspection
- Quick change structure of probe and delay line
- IHC for irrigation, holes, carbides of delay line
- IHS stands for delay block with water inlet, clamping holes at both sides and stainless steel structure.

Applications

- Plate butt weld inspections
- Directional irregular defects
- Near surface defects detection



Specifications

Model	Frequency (MHz)	Size (Φ/mm)	Type	Interface	Standard
TF	2.25/3.5/5/7.5/10/15	3/6/10/12	C	L5	ASTM E-1065



04

CONVENTIONAL PROBE

High Temperature Delay Line Probes



Single crystal probe with a replaceable delay line, applied for high temperature detection environment.

Features

- ✓ Supply 0° (ZH type) longitudinal incidence and 45°/ 60°/70° (AH type) shear wave incidence delay lines
- ✓ Supply 13 / 25 / 38mm three ZH types standard height delay lines, and 45°/60°/70° three shear wave AH types delay lines
- ✓ Two types of delay lines:
HT1: maximum 20s on workpiece at 200 °C(392 °F)
HT2: maximum 10s on workpiece at 300 °C(572 °F)
- ✓ Quick change structure of delay line and probe
- ✓ Standard lengths of ZH type delay line matching with probes:
Φ10 mm (0.375 in) crystal probe with 13 mm (0.5 in) delay line
Φ13/19 mm (0.5/0.7 in) crystal probe with 25 mm (1.0 in) delay line
- ✓ Probe face can be processed into different shapes to ensure good coupling with workpiece
- ✓ Top mounting Microdot (L5) connector

Attention:

1. When reach maximum contact time, probe is required to cool down to room temperature to working again.
2. The contact time is related to the contact temperature. For the specific relationship between them, please consult with Doppler transducer expert.

Applications

- ✓ Intermittent contact detection with high temperature workpiece (castings, forgings etc.)
- ✓ Direct flaw detection
- ✓ Detection of curved surface of workpiece



Specifications

Model	Frequency (MHz)	Size (Φ/mm)	Type	Interface	Standard
HT	2.25/5	6/10/13/19	PL	L5	ASTM E-1065

Type	Temperature resistance (°C/°F):Maximum operating time (s)	
	HT1	HT2
ZH	(170°C/338°F) /10	(500°C/932°F) /10
AH	(130°C/266°F) /10	(270°C/518°F) /10

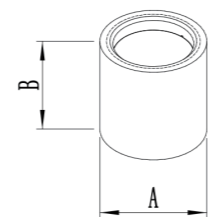

ZH type

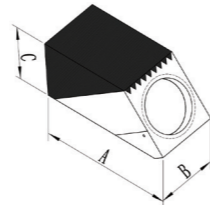

AH type

Thickness Measurement Probes



Doppler provides an existing solution for most corrosion application sites, providing a complete set of twin- crystal and single-crystal thickness measuring probes for thickness measurement of workpiece, work with Accur 1/3/5 different thickness measuring instruments, to ensure the accuracy of thickness measurement to the greatest extent; besides the measurement of corrosion wall thickness, it can also be used for small diameter pipelines, etc. Measurement and application of tubing, boiler tube wall, penetrating coating, spot weld integrity, probes with different frequencies, contact sizes and special high temperature applications are available for selection.



Specifications

Model	Application	Frequency MHz	Bottom Contact OD		Range		Operation TEMP		Line-out	Connector	Cable (option)	Accur-*(option)
			mm	in	mm	in	°F	°C				
MT5096	Standard/Normal	5	11.5	0.45	1.5-50	0.4-2.0	-4 +140	-20 +60	Top	Microdot	1GC0515 1GC0516 1GC0520	1
MT211	Standard/Normal	2	16.5	0.65	2-225	0.079-8	-4 +140	-20 +60	Side	Lemo-00	1GC0422	1/5
MT211H*	Standard/Normal	2	16.5	0.65	3-200	0.12-7.87	+32 +932	0 +500	Top	Lemo-00	1GC0422	1/5
MT211L	Fingertips/Normal	2	15.5	0.61	2-225	0.079-8.0	-4 +140	-20 +60	Side	Lemo-00	withCable 1.5m	1/5
MT121	Standard/Normal	1	28.5	1.12	8-80	0.31-3.15	-4 +140	-20 +60	Side	Lemo-00	1GC0422	1/5
MT105H*	Standard/Normal	10	7.5	0.30	1.2-30	0.047-1.18	+32 +932	0 +500	Top	Lemo-00	1GC0422	1/5
MT509	Standard/Normal/Through Coating	5	11.5	0.45	1.5-225 (Through Coating 3~100)	0.06-8.0 (Through Coating 0.19~3.93)	-4 +140	-20 +60	Side	Lemo-00	1GC0422	1
MT509H*	Standard/Normal	5	11.5	0.45	2-200	0.079-7.87	+32 +932	0 +500	Top	Microdot	1GC0478 1GC0514 1GC0520	1
MT506	Fingertips/Normal/Through Coating	5	7.5	0.30	1.5-225 (Through Coating 5~20)	0.05-8.6 (Through Coating 0.2~0.79)	-4 +140	-20 +60	Side	Microdot	1GC0424	1
MT506L	Fingertips/Normal/Through Coating	5	9.5	0.37	1.5-225 (Through Coating 5~20)	0.05-8.6 (Through Coating 0.2~0.79)	-4 +140	-20 +60	Side	Lemo-00	withCable 1.2m	1
MT102L	Fingertips/Normal	10	3.0	0.12	1-8	0.04-0.31	-4 +140	-20 +60	Side	Lemo-00	withCable 1.5m	1/5
MT105	Fingertips/Normal	10	7.5	0.30	0.8-50	0.03-1.97	-4 +140	-20 +60	Side	Microdot		1/5
MT105L	Fingertips/Normal	10	7.2	0.28	0.8-50	0.03-1.97	-4 +140	-20 +60	Side	Lemo-00	withCable 1.5m	1/5

04

CONVENTIONAL
PROBE

High Frequency Probes



High frequency probe refers to a single element transducer with a frequency higher than 20MHz, which includes HF contact probe, HF immersion probe and HF immersion self-focusing probe.

Features

- ✓ Both contact probes and immersion probes have integrated delay lines, and self-focusing immersion probes do not have delay lines or lens
- ✓ The frequency range is 20 ~ 50MHz
- ✓ With broadband and narrow pulse performance, the probe has excellent near surface resolution and vertical and horizontal resolution
- ✓ A very small focal spot diameter in the near field or focus point
- ✓ Side mounted microdot connector for contact probe by default, and top mounted UHF interface for immersion probe and immersion self-focusing probe by default

Applications

- ✓ Minor cracks on the surface
- ✓ High resolution detection effect is required, such as the ability to find small cracks or pores
- ✓ With the ideal surface condition, temperature and excitation setting, the thinnest thickness that 50MHz probe can reach in steel is 0.05 mm (0.0019 in) in thickness measurement mode
- ✓ Scanning acoustic microscope

Specifications

Model	Frequency (MHz)	Size (Φ/mm)	Type	Interface	Standard
HFN	20/30/50	6	/	LS	ASTM E-1065

Immersion probe

Immersion Probes

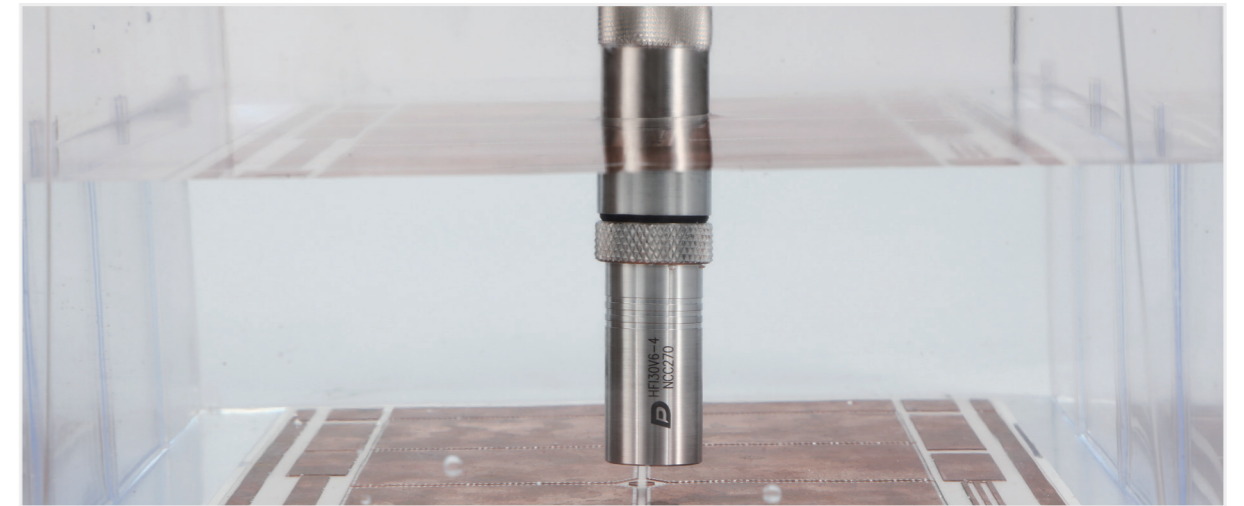

Probe is design for total or partial immersion into water or other liquids to create ultrasonic beams.

Features

- ✓ Strong pressure and corrosion resistance
- ✓ Excellent acoustic impedance in water or other liquids, 1/4 wavelength of matching layer can ensure maximum power outputs
- ✓ No coupling issues between probe and liquid
- ✓ There are three different configurations: unfocused probes (planar), Point focused probe (spherical surface), and Line focused probe (cylindrical surface) Another form of focusing is wafer self-focusing, which has a finer focusing area and is a custom product, limited to piezoelectric composite ceramics (c)
- ✓ Three types of performance probes can meet most of detection needs "PL" Universal Series, "PH" Short Pulsing Series, "C" Composite Series

Applications

- ✓ Unfocused probes (planar) are used for general applications and penetrating thicker materials
- ✓ Point focused probe (spherical surface) is generally used to improve the sensitivity and signal-to-noise ratio of small flaw deflection
- ✓ Line focused probe (cylindrical surface) is generally used for the detection of pipes and bars
- ✓ Online thickness measurement; Automatic scanning; Material analysis; Imaging system



04

CONVENTIONAL PROBE

European Standard - I1

- Top mounting with 1.8 meter or 2.5 meter cable length, cable end with Lemo 01 (C9) connector

Model	Frequency (MHz)	Size (Φ/mm)	Type	Interface	Standard
I1	1/2/4/5/10/15	5/10/20	PL/PH/C	C9 (zone line)	EN ISO 22232-2



North America Standard - I2

- Top mounting UHF waterproof connector

Model	Frequency (MHz)	Size (Φ/mm)	Type	Interface	Standard
I2	0.5/1/2.25/3.5/5/7.5/10/15/20/25	3/6/10/13/19/25/29/38	PL/PH/C	UHF	ASTM E-1065



North America Standard - I3

- 9.7mm (0.375in) outer diameter, suitable for limited detection environment
- Top mounting Microdot (L5) non-waterproof connector

Model	Frequency (MHz)	Size (Φ/mm)	Type	Interface	Standard
I3	2.25/3.5/5/10/15/20/25	3/6	PL/PH	L5	ASTM E-1065



North America Standard - I4

- 9.4mm (0.37in) outer diameter, 51mm (2in) length, suitable for hard to reach detection areas
- Top mounting UHF waterproof connector

Model	Frequency (MHz)	Size (Φ/mm)	Type	Interface	Standard
I4	2.25/3.5/5/10/15/20/25	3/6	PL/PH	UHF	ASTM E-1065



North America Standard - I5

- Cuboid profile, sound wave direction and connector into a 90 degree, for specific application environment
- Top mounting UHF waterproof connector

Model	Frequency (MHz)	Size (Φ/mm)	Type	Interface	Standard
I5	1/2.25/3.5/5/10	6/10/13	PL/PH/C	UHF	ASTM E-1065



High Frequency Probes



High frequency probe refers to a single element transducer with a frequency higher than 20MHz, which includes HF contact probe, HF immersion probe and HF immersion self - focusing probe.

Features

- Both contact probes and immersion probes have integrated delay lines, and self - focusing immersion probes do not have delay lines or lens
- The frequency range is 20 ~ 50MHz
- With broadband and narrow pulse performance, the probe has excellent near surface resolution and vertical and horizontal resolution
- A very small focal spot diameter in the near field or focus point
- Side mounted microdot connector for contact probe by default, and top mounted UHF interface for immersion probe and immersion self- focusing probe by default

Applications

- Minor cracks on the surface
- High resolution detection effect is required, such as the ability to find small cracks or pores
- With the ideal surface condition, temperature and excitation setting, the thinnest thickness that 50MHz probe can reach in steel is 0.05 mm (0.0019 in) in thickness measurement mode
- Scanning acoustic microscope

Specifications

Model	Frequency (MHz)	Size (Φ/mm)	Type	Interface	Standard
HFI	20/30/50	3/6	/	UHF	ASTM E-1065

04

CONVENTIONAL PROBE

Hyperbolic Ultrasonic Transducer

The main feature of Hyperbolic sensor is its aspheric focusing active surface, which is usually larger than traditional sensors. The definition of transducer is determined by calculation, which defines a surface from which every point flies to the defect at the same time. The sensor is dedicated to a specific setting.

Some key components that must be inspected by non-destructive methods are made of materials that are considered difficult to be machined by ultrasonic waves because of their poor attenuation or uniformity, such as titanium or austenitic steel. The size and depth (sometimes size) of the defect to be detected need high lateral resolution, and the combination of high lateral resolution, long acoustic path and low frequency makes it necessary to use large aperture and focusing transducer. Inspection is usually carried out through an interface with defocusing effect. In order to improve the performance of these difficult inspections, an aspheric focusing transducer is designed to focus on a precise point in a given specific material through a toric interface to achieve specific detection needs.

Hyperbolic Ultrasonic Transducer



Through the plane, cylinder or ring interface, the effective focusing area of aspheric surface is calculated to achieve the best focusing effect at a given refraction angle at a specific position in the material.

The broadband transducer aperture combined with the hyperboloid can significantly improve the lateral resolution and signal-to-noise ratio.

This technology usually adopts immersion pulse echo method for detection.

Features

- Piezoelectric composite technology
- Center frequency (-6dB): 1 MHz to 10MHz
- Relative bandwidth (-6dB): 60% to 90%
- Acoustic impedance matching: acoustic impedance matches water. Compared with monolithic piezoelectric ceramics, this leads to better energy transfer, and combined with strong electro-acoustic performance, the sensitivity level is improved by 10 to 50dB.
- Waterproof stainless steel shell and waterproof UHF connector

Applications

- Detection of thick-walled parts and heterogeneous materials
- Multi-area blank inspection
- Thick plate detection
- Inspection of heavy forgings
- Nuclear container inspection

Advantage

- Ultra-high resolution and signal-to-noise ratio
- Based on piezoelectric composite technology, the beam morphology is highly consistent with the simulation
- Hyperbolic surfaces support flexible high-resolution beam focusing and scanning

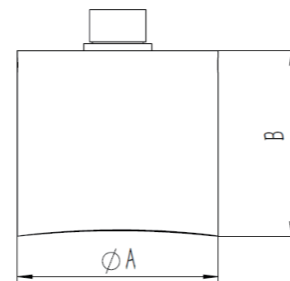

Simulation of sound field CIVA: underwater sound field in XZ and YZ respectively.

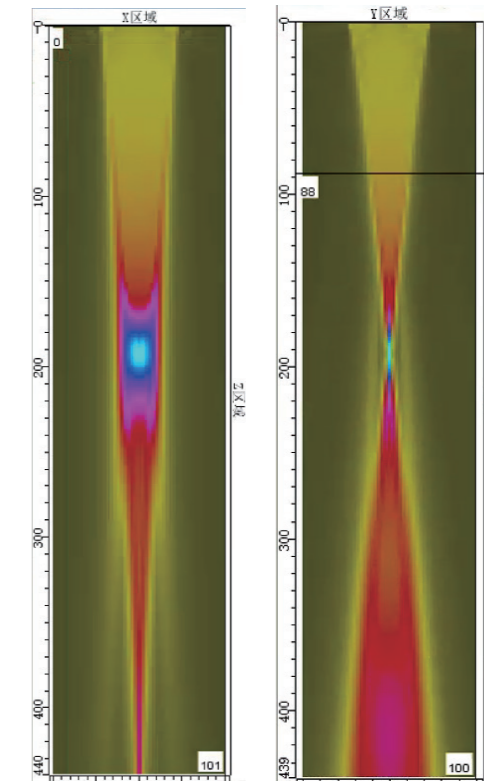

Specifications

Model	Frequency (MHz)	Size		Specification	Size	
		mm	In		ODA mm	HeightB mm
9PSFC48X13 (ITEM1)	7.5	13	0.5"	0.4" in 8"	38	52
9PFIC306X45 (ITEM4)	5	45	1.75"	3.0" in 6"	56	52
9PFIC318X45 (ITEM7)	5	45	1.75"	3.1" in 8"	56	52
9PFIC1310X32 (ITEM9)	5	32	1.25"	1.3" in 10"	45	52
9PFIC2210X38 (ITEM10)	5	38	1.5"	2.2" in 10"	51	53
9PFIC3110X45 (ITEM11)	5	45	1.75"	3.1" in 10"	56	52

Air-coupling Probes

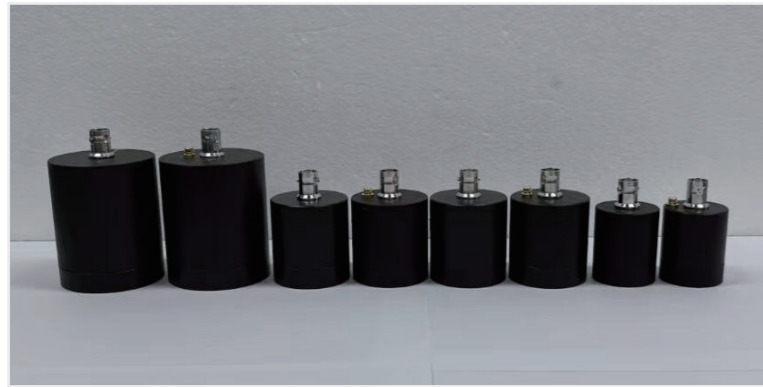

Features

- ✓ Non-contact, non-invasive, completely intact;
- ✓ High sensitivity and high signal-to-noise ratio;
- ✓ A 60dB preamplifier is built in the receiver to achieve higher system integration.
- ✓ Different apertures and different focal lengths can be customized according to user's needs.

Specifications and Dimensions

Model	Frequency(KHz)	Active Aperture(mm)	Focus	Standard Interface	Operating Mode
AB0.65C13NF-T	650	13	NO	BNC	Emission
AB0.65C13NF-R	650	13	NO		Receive
AB0.42C24NF-T	420	24	NO		Emission
AB0.42C24NF-R	420	24	NO		Receive
AB0.25C24NF-T	250	24	NO		Emission
AB0.25C24NF-R	250	24	NO		Receive
AB0.13C36NF-T	130	36	NO		Emission
AB0.13C36NF-R	130	36	NO		Receive
AB0.4C24BF50-T	400	24	50		Emission
AB0.4C24BF50-R	400	24	50		Receive

Applications

- ✓ Testing of composite materials (CFRP/GFRP, honeycomb, ceramic matrix, etc.);
- ✓ Detection of lithium ion battery (electrolyte distribution, air layer);
- ✓ Strength detection of reinforced concrete members;
- ✓ Other materials that are not suitable for coupling agents.

Probes for Custom and Specific Applications

From the beginning of Doppler, it has always been our advantage to provide customers with custom and special probes design, and leading the probe technique frontiers. To understand customers' demands and application requests, our experienced application engineers, probe design experts work together with our customers, using the best way to provide perfect application solutions and product designs, to meet & satisfy the demands of challenging ultrasonic market.

Low Frequency Normal Probe



The frequency of these probes is usually between 0.05 ~ 0.25MHz. The ultra-low frequency ensures good penetration and signal-to-noise ratio in some attenuation materials such as stone, wood, rubber and concrete.

Hollow Focusing Probe

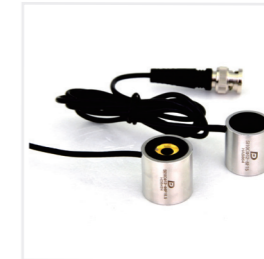

Polymer thin film element makes annular self focusing a reality. In the application of imaging system, the probe is used to receive laser beam.

LW + SW Dual Waveforms Probe



The probe has two channels, which excite SW and LW respectively, it is used for the measurement of material parameters, such as elastic modulus, shear modulus, Poisson's ratio and sound velocity.

LW Angle Probe



The angles of LW angle probe can be 45 ° / 60 ° / 70 °. Compared with the traditional designed probe, this probe has almost no interference of initial blind area in detection.

Dual Creeping Wave Focusing Probe



Used for the detection of pillar ceramic insulator materials in power industry.

Plate Wave Probe



Used to generate plate waves in thin plates.

I2 Immersion Probe Mirror



This mirror is used to guide the sound beam by 90° refraction.

I2 Immersion Probe Extension Rod



This extension rod can be used for UHF-interfaced immersion probe extensions.

04

CONVENTIONAL PROBE

Low Temperature Thickness Probe

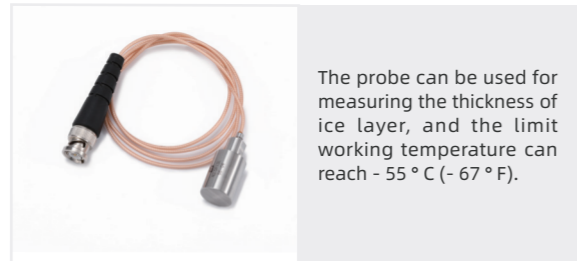

The probe can be used for measuring the thickness of ice layer, and the limit working temperature can reach - 55 °C (- 67 °F).

Water Wedge Bimorph Straight Probe

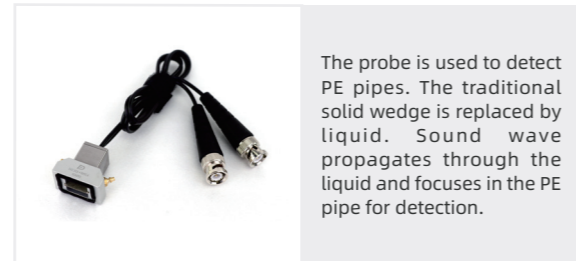

The probe is used to detect PE pipes. The traditional solid wedge is replaced by liquid. Sound wave propagates through the liquid and focuses in the PE pipe for detection.

Aluminum Measurement Angle Probe



This probe is used for welding inspection of aluminum materials.

Special Probe With Guide Rail Slot

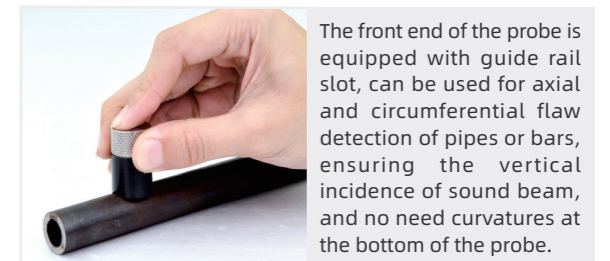

The front end of the probe is equipped with guide rail slot, can be used for axial and circumferential flaw detection of pipes or bars, ensuring the vertical incidence of sound beam, and no need curvatures at the bottom of the probe.

Variable Angle Probe



Used for measuring the angle and performance before finalizing products, and the angle is adjustable from 0 ~ 90 °.

1T3R steel plate inspection probe

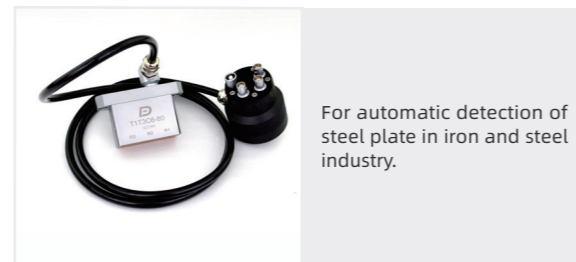

For automatic detection of steel plate in iron and steel industry.

Hollow Shaft Detection Probe

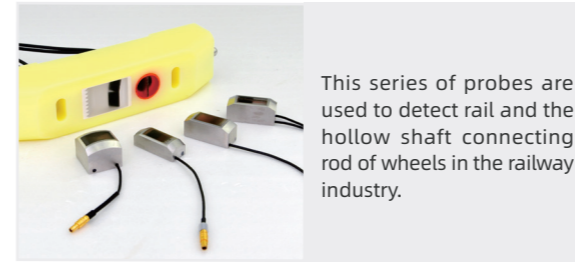

This series of probes are used to detect rail and the hollow shaft connecting rod of wheels in the railway industry.

High Frequency Water Filling Probe

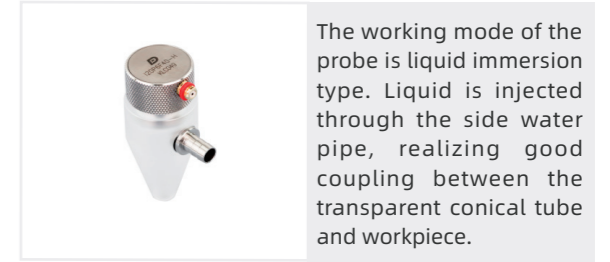

The working mode of the probe is liquid immersion type. Liquid is injected through the side water pipe, realizing good coupling between the transparent conical tube and workpiece.

High Frequency Immersion Probe

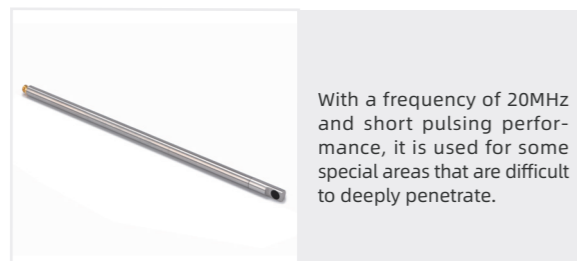

With a frequency of 20MHz and short pulsing performance, it is used for some special areas that are difficult to deeply penetrate.

Special Immersion Probe

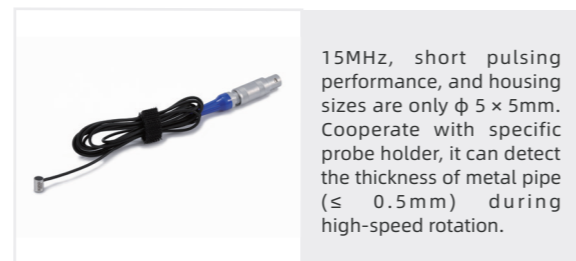

15MHz, short pulsing performance, and housing sizes are only $\phi 5 \times 5$ mm. Cooperate with specific probe holder, it can detect the thickness of metal pipe (≤ 0.5 mm) during high-speed rotation.

Special Dual Element Straight Probe

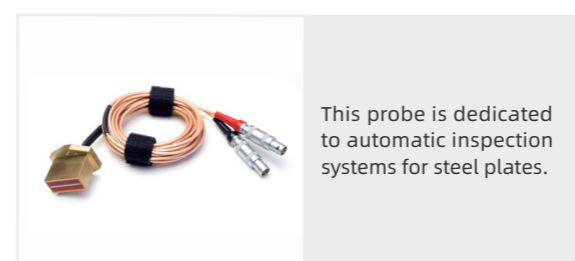

This probe is dedicated to automatic inspection systems for steel plates.

Wheeled Industrial Probe

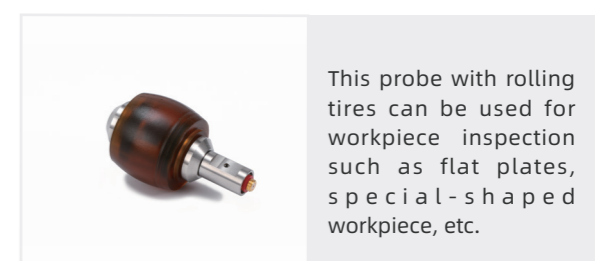

This probe with rolling tires can be used for workpiece inspection such as flat plates, special-shaped workpiece, etc.

Special Probe With Handle

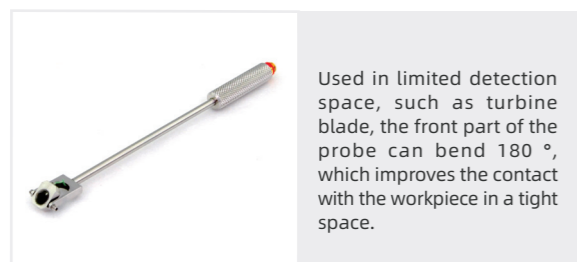

Used in limited detection space, such as turbine blade, the front part of the probe can bend 180 °, which improves the contact with the workpiece in a tight space.

High Temperature Resistant dual Probe

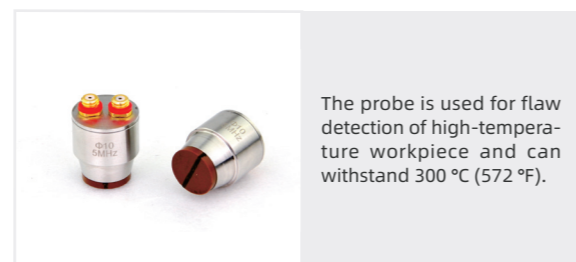

The probe is used for flaw detection of high-temperature workpiece and can withstand 300 °C (572 °F).

1T2R Critical Angle Probe

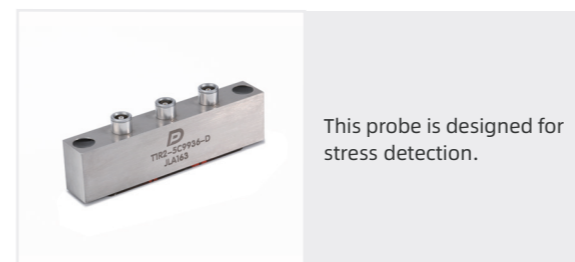

This probe is designed for stress detection.

System Matching Probe

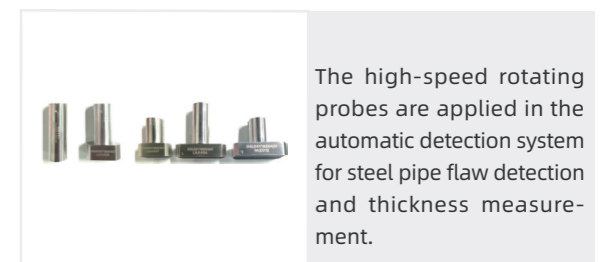

The high-speed rotating probes are applied in the automatic detection system for steel pipe flaw detection and thickness measurement.

04

CONVENTIONAL
PROBE

Cables

The probe cable is composed of a coaxial cable (wire + insulating layer + shielding network) and two connectors respectively connecting the probe and the instrument, which is used for electrical signal transmission between instrument and probe. Commonly used connectors include BNC (Q9), Microdot (L5), Lemo-00 (C5), Lemo-1 (C9), etc. Coaxial cable include RG174, RG178, RG 316, RG58, etc. Unless specified, the impedance value of all cables is 50 ohms.



- Lemo-1(Water proof)
- UHF(Water proof)
- Lemo-1(C9)
- Lemo-1 Coupling
- Lemo-00(C5)
- BNC(Q9)
- BNC(Q6)
- Microdot(L5)
- 16MCX((Right angle)
- Lemo mini

Features

- "A" and "B" represent the interfaces at the two ends of the cable respectively
- Cable length can be customized
- Customize special cables available
- * Indicates that the cable is the original Lemo connector

Specifications

Cable No.	Code	Connector Type		Cable	Length (m/ft)	Cable No.	Code	Connector Type		Cable	Length (m/ft)	
		A	// B					A	// B			
Single	1GC0017	BNC(Q9)	BNC(Q9)	RG174	1.8 / 6	Single	1GC0001	Lemo-00(C5)	Lemo-00(C5)	RG174	1.8 / 6	
	1GC0016	BNC(Q9)	BNC(Q6)	RG174	1.8 / 6		1GC0461 *	Lemo-00(C5)	Lemo-00(C5)	RG174	1.8 / 6	
	1GC0013	BNC(Q9)	Lemo-00(C5)	RG174	1.8 / 6		1GC0002	Lemo-00(C5)	Microdot(L5)	RG174	1.8 / 6	
	1GC0450 *	BNC(Q9)	Lemo-00(C5)	RG174	1.8 / 6		1GC0319 *	Lemo-00(C5)	Microdot(L5)	RG174	1.8 / 6	
	1GC0015	BNC(Q9)	Lemo-1(C9)	RG174	1.8 / 6		Dual	1GC0089	BNC(Q9)×2	BNC(Q9)×2	RG174	1.8 / 6
	1GC0441 *	BNC(Q9)	Lemo-1(C9)	RG174	1.8 / 6			1GC0039	BNC(Q9)×2	BNC(Q9)×2	RG174	1.8 / 6
	1GC0451	BNC(Q9)	Lemo-1 (Waterproof)	RG58	1.8 / 6	1GC0027		BNC(Q9)×2	Lemo-00(C5)×2	RG174	1.8 / 6	
	1GC0452	BNC(Q9)	Lemo-1 Coupling	RG174	1.8 / 6	1GC0462 *		BNC(Q9)×2	Lemo-00(C5)×2	RG174	1.8 / 6	
	1GC0453	BNC(Q9)	Lemo mini	RG178	1.8 / 6	1GC0155		BNC(Q9)×2	Lemo-1(C9)×2	RG174	1.8 / 6	
	1GC0018	BNC(Q9)	Microdot(L5)	RG174	1.8 / 6	1GC0463 *		BNC(Q9)×2	Lemo-1(C9)×2	RG174	1.8 / 6	
	1GC0502	BNC(Q9)	UHF(Waterproof)	RG58	1.8 / 6	1GC0028		BNC(Q9)×2	Microdot(L5)×2	RG174	1.8 / 6	
	1GC0455	BNC(Q9)	16MCX(Right angle)	RG174	1.8 / 6	1GC0464		BNC(Q9)×2	Lemo mini×2	RG178	1.5 / 4.9	
	1GC0007	Lemo-1(C9)	Lemo-1(C9)	RG174	1.8 / 6	1GC0152		Lemo-1(C9)×2	Lemo-1(C9)×2	RG174	1.8 / 6	
	1GC0456 *	Lemo-1(C9)	Lemo-1(C9)	RG174	1.8 / 6	1GC0465 *		Lemo-1(C9)×2	Lemo-1(C9)×2	RG174	1.8 / 6	
	1GC0457	Lemo-1(C9)	Lemo-1(Waterproof)	RG58	1.8 / 6	1GC0024		Lemo-1(C9)×2	Lemo-00(C5)×2	RG174	1.8 / 6	
	1GC0458	Lemo-1(C9)	Lemo-1 Coupling	RG174	1.8 / 6	1GC0466 *		Lemo-1(C9)×2	Lemo-00(C5)×2	RG174	1.8 / 6	
	1GC0006	Lemo-1(C9)	Lemo-00(C5)	RG174	1.8 / 6	1GC0025		Lemo-1(C9)×2	Microdot(L5)×2	RG174	1.8 / 6	
	1GC0442 *	Lemo-1(C9)	Lemo-00(C5)	RG174	1.8 / 6	1GC0467 *		Lemo-1(C9)×2	Microdot(L5)×2	RG174	1.8 / 6	
	1GC0008	Lemo-1(C9)	Microdot(L5)	RG174	1.8 / 6	1GC0468	Lemo-1(C9)×2	Lemo mini×2	RG178	1.5 / 4.9		
	1GC0443 *	Lemo-1(C9)	Microdot(L5)	RG174	1.8 / 6	1GC0122	Lemo-00(C5)×2	Lemo-00(C5)×2	RG174	1.8 / 6		
1GC0500	Lemo-1(C9)	UHF(Waterproof)	RG58	1.8 / 6	1GC0469 *	Lemo-00(C5)×2	Lemo-00(C5)×2	RG174	1.8 / 6			
1GC0501 *	Lemo-1(C9)	UHF(Waterproof)	RG58	1.8 / 6	1GC0106	Lemo-00(C5)×2	Microdot(L5)×2	RG174	1.8 / 6			
1GC0460	Lemo-1(C9)	Lemo mini	RG178	1.5 / 4.9	1GC0470 *	Lemo-00(C5)×2	Microdot(L5)×2	RG174	1.8 / 6			

Adapters

The adapter can achieve fast switching between different instruments, probes, and connecting wires.

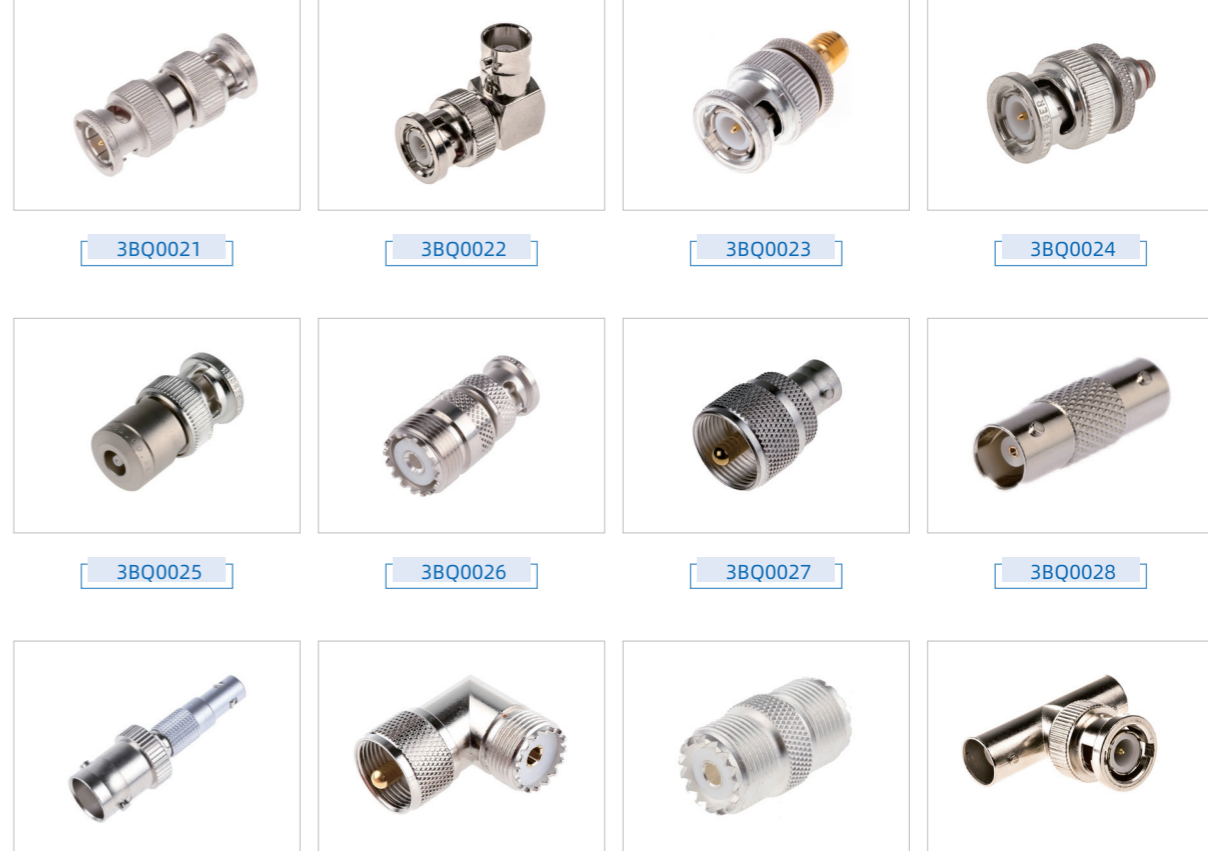

- 3BQ0021
- 3BQ0022
- 3BQ0023
- 3BQ0024
- 3BQ0025
- 3BQ0026
- 3BQ0027
- 3BQ0028
- 3BQ0030
- 3BQ0031
- 3BQ0032
- 3BQ0033

Specifications

Model	Interface Type	Model	Interface Type	Model	Interface Type
3BQ0021	BNC Male – BNC Male	3BQ0025	BNC Male – Lemo00 Female	3BQ0030	BNC Female – Lemo00 Male
3BQ0022	BNC Male – BNC Female (right angle)	3BQ0026	BNC Male – UHF Female	3BQ0031	UHF Male – UHF Female (right angle)
3BQ0023	BNC Male – SMA Female	3BQ0027	BNC Female – UHF Male	3BQ0032	UHF Female – UHF Female
3BQ0024	BNC Male – Microdot Female	3BQ0028	BNC Female – BNC Female	3BQ0033	BNC Male – 2×BNC Female